

R1T + R1S

# Tow Operator Guide

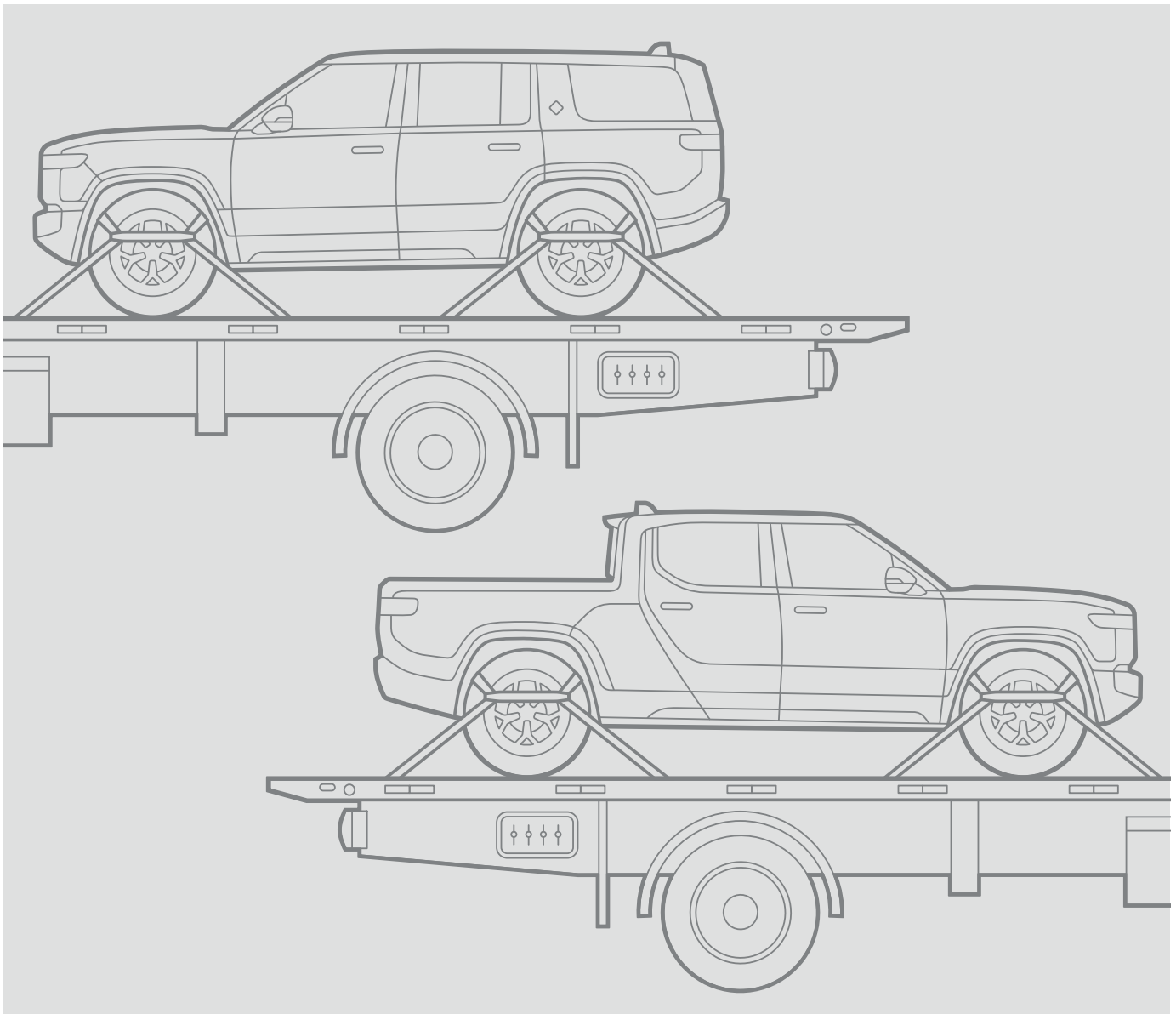



© 2021-2023 Rivian Automotive, LLC. All rights reserved.

All information in this document and all Rivian software is subject to copyright and other intellectual property rights of Rivian Automotive, LLC, its affiliates, or its licensors. This material may not be modified, reproduced, or copied, in whole or in part, without the prior written permission of Rivian Automotive, LLC, its affiliates, or its licensors. Unless indicated otherwise, all trademarks are owned and registered by Rivian Automotive, LLC, its affiliates, or its licensors in the United States and/or other countries. Please visit <https://www.rivian.com/legal/brand> for Rivian's trademarks and service marks.

Software embedded or accessed by the vehicle may utilize open source software. Please visit <https://www.rivian.com/legal/open-source> for more information.

Some features may not be available depending on your vehicle configuration or region.

The images provided in this document are for illustrative purposes only. Depending on the product details and market region, the information in this document may appear slightly different from your product.

# Contents

<b>Change a Tire</b> .....	<b>4</b>
Prepare the Vehicle .....	4
Prepare the Spare Tire .....	5
Lift the Vehicle with the Tire Service Kit .....	8
Remove and Replace a Wheel .....	11
Remove a Wheel .....	11
Install a New Wheel .....	11
Store the Removed Wheel .....	12
<b>Lift the Vehicle with a Non-Rivian Jack</b> .....	<b>13</b>
Prepare to Lift the Vehicle .....	13
Remove the Front Panels .....	15
Remove the Rear Panels .....	16
Jack and Lift the Vehicle .....	17
Reinstall the Panels .....	18
<b>Transport the Vehicle</b> .....	<b>19</b>
Prepare the Vehicle for Towing .....	19
Connect to the Trailer Hitch .....	21
Lift the Rear Wheels .....	22
Load the Vehicle onto the Tow Truck .....	24
Vehicle Shipping Mode .....	26
<b>Manually Open the Hood</b> .....	<b>27</b>
<b>Manually Release the Charge Plug</b> .....	<b>29</b>
<b>Jump-Start the 12 V Batteries</b> .....	<b>30</b>
Jump-Start the Primary 12 V Battery .....	31
Jump-Start the Secondary 12 V Battery .....	32
<b>Perform a Restart</b> .....	<b>35</b>
Restart the Software .....	35
Restart the Vehicle .....	36
<b>Reset the Windows</b> .....	<b>37</b>
<b>Disable the High-Voltage System</b> .....	<b>38</b>
<b>Customer Service</b> .....	<b>40</b>

# Change a Tire



## DANGER

Don't place any part of your body under the vehicle while it's lifted.



## WARNING

- Don't service the vehicle on a narrow shoulder, near oncoming traffic, or on soft terrain.
- Ensure the surface is flat, firm, and high-friction.
- Don't place the tire jack over a grate or manhole cover.





## CAUTION

The Rivian Tire Service Kit should only be used for roadside emergencies to change a flat or damaged tire on a Rivian vehicle. [Contact Rivian](#) for other types of service or repair.

## NOTE

The full-size spare tire, compact spare tire, and tire service kit are optional items and must be purchased separately.

## PREPARE THE VEHICLE

1. Find a safe, level location.
2. Go to **Drive Modes** . Choose **All-Purpose** , and then choose **Standard** under **Ride Height**.
3. Ensure the vehicle is in **Park**.
4. Turn on the hazard lights.

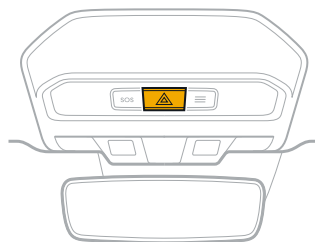

5. Ensure all passengers exit the vehicle and stay in a safe location.
6. Secure the vehicle by placing wheel chocks diagonally opposite the tire to be changed.



## WARNING

The electronic park brake is only on the rear wheels. If you lift a rear wheel, the vehicle may roll.

## PREPARE THE SPARE TIRE

1. For R1T, access the spare tire compartment in the truck bed.

a. Ensure that the truck bed is empty, and that there aren't any objects on the lid.

**NOTE**

Unlock and remove the rear Cargo Crossbar if needed. The owner must provide the key.

b. Open the tailgate.

c. Lift the release lever to open the spare tire compartment. Push the spare tire compartment lid to a vertical position to remove the spare tire.

d. Push the spare tire compartment lid to a vertical position to remove or replace the spare tire.

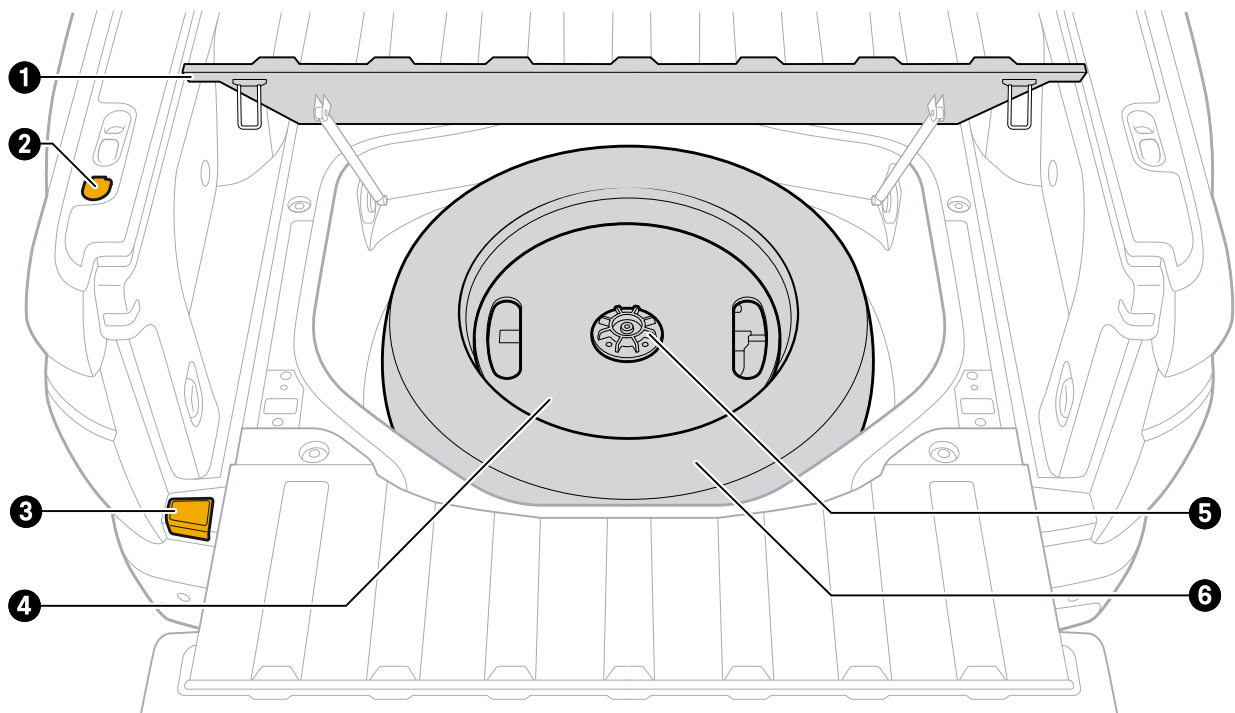

Item	Description
1	Spare tire compartment lid
2	Tailgate release button
3	Spare tire compartment release lever
4	Tire service kit
5	Spare tire wing nut
6	Spare tire

## CHANGE A TIRE

---

2. For R1S, access the spare tire compartment in the rear cargo area.
  - a. Open the upper liftgate and tailgate.
  - b. Ensure the rear cargo area is empty.
  - c. Use the handle to lift the floor panel door.
  - d. Remove the cargo tray.

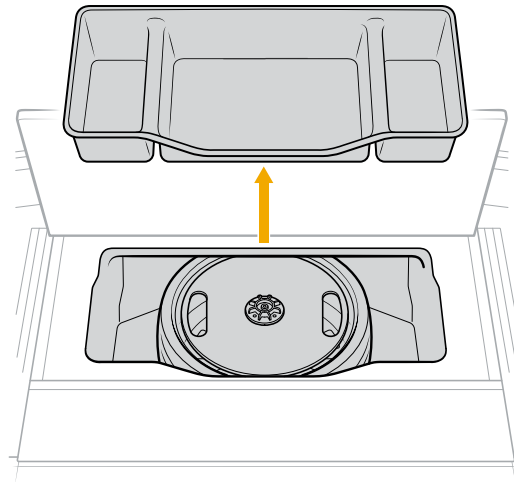
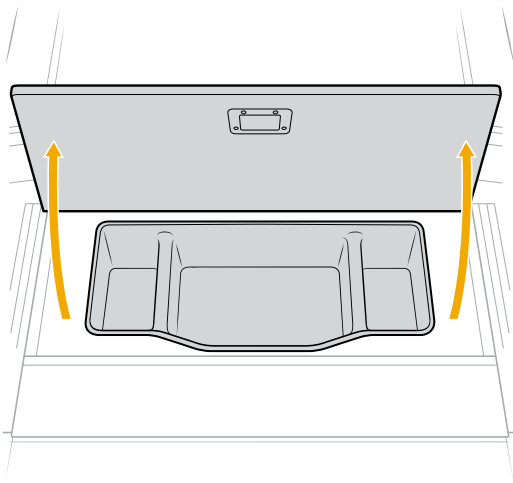

3. Remove the tire service kit from the spare tire.
  - a. Unfasten the spare tire wing nut and remove the tire service kit.
  - b. Use the hex hole on the spare tire wing nut to unscrew and remove the tire service kit retention rod.

**R1T**

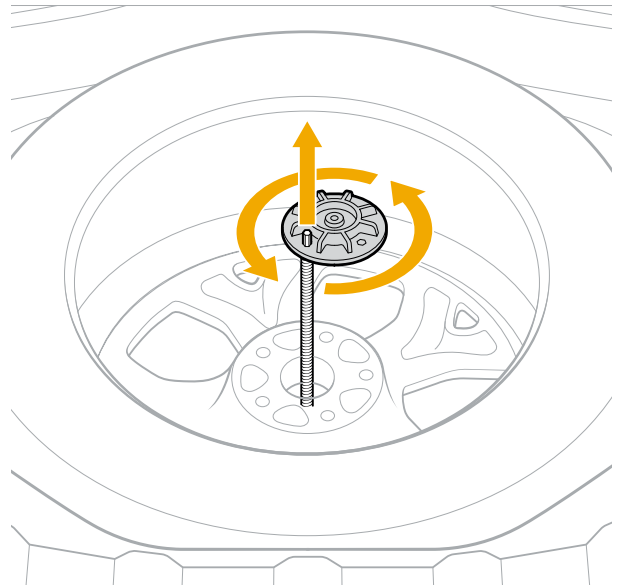
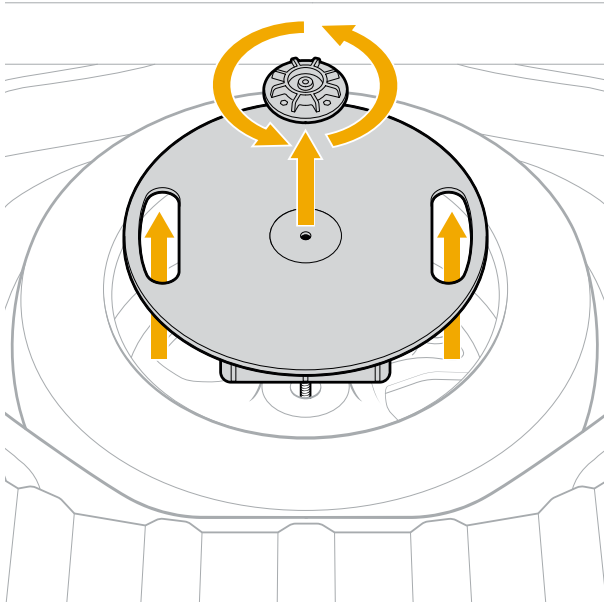

**R1S**

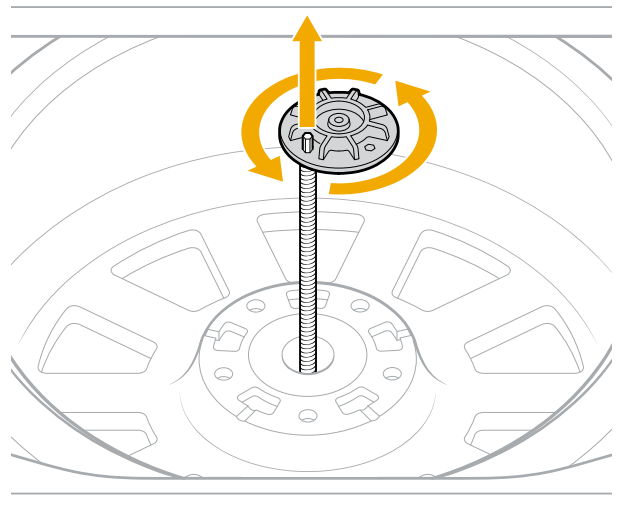
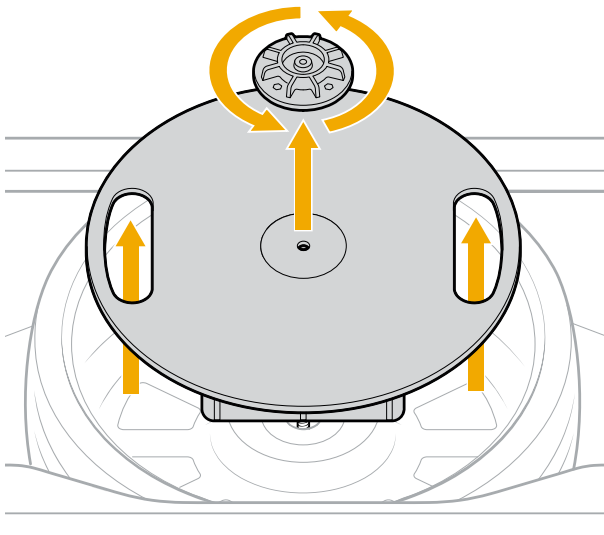

- c. Save the wing nut and retention rod for reinstallation.
4. Remove the spare tire.



5. If you're using the full-size spare tire, inflate the tire to the recommended pressure (listed on the Tire and Loading Information label on the driver's door pillar).



### CAUTION

Inflate the compact spare tire after you install it on the vehicle. See [Remove and Replace a Wheel](#) (page 11).

## LIFT THE VEHICLE WITH THE TIRE SERVICE KIT

1. Go to **Drive Modes**  in the center display. Choose **Off-Road All-Terrain** . Then choose **Highest** under **Ride Height**.
2. Go to **Settings** . Choose **Vehicle**. Then choose **Service**. Turn on **Tire Change** mode.

### NOTE

Automatic suspension adjustments pause when **Tire Change** mode is on. Also, ride height can't be changed when **Tire Change** mode is on.

3. Locate the vehicle jack point. There are two jack points on each side under the rocker panel.

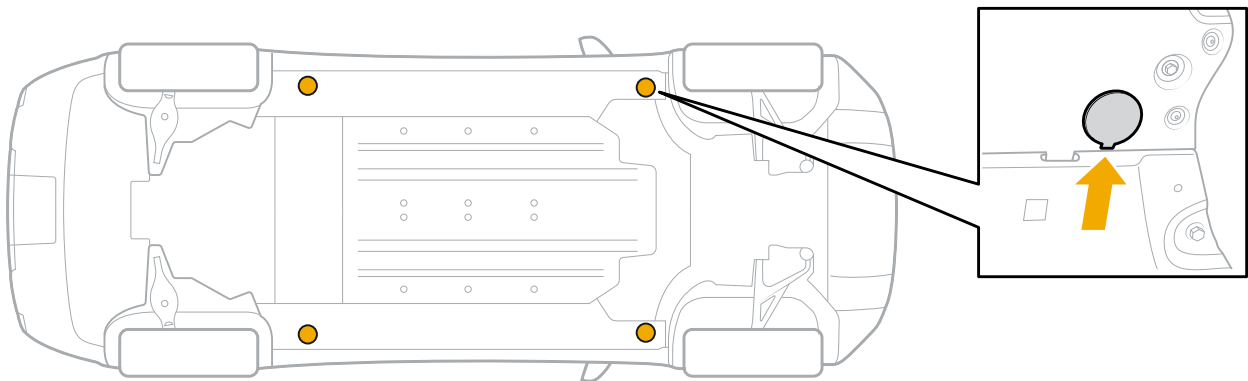

4. Remove the jack point cover by applying force to the inner edge.
5. If replacing a rear tire, slide the jack riser base (3) out of the storage disc (4) included in the tire service kit. Then place the jack on top of the riser base.

### NOTE

If replacing a front tire, don't use the riser base.



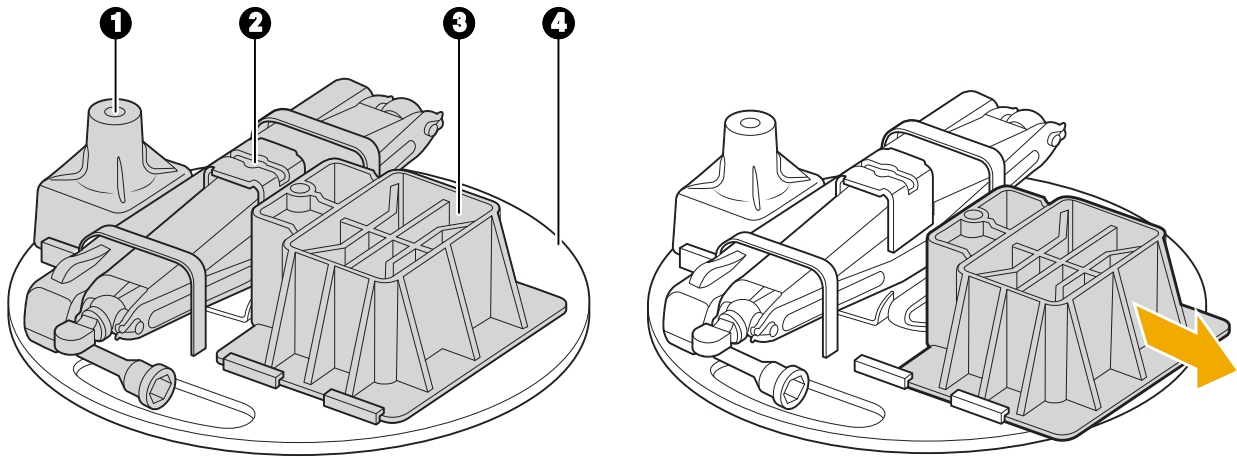

Item	Description
1	Jack adapter
2	Tire jack
3	Jack riser base
4	Storage disc



**CAUTION**

Always use the jack adapter to prevent damage to the vehicle when you lift the vehicle with the Rivian-supplied tire jack.

Don't use the jack adapter with other scissor or hydraulic jacks.

6. Align the top of the jack adapter (1) with the hole at the vehicle jack point.
7. Place the tire jack (2) under the jack adapter.

**NOTE**

Don't place the storage disc under the tire jack.

8. Assemble the jack handle.

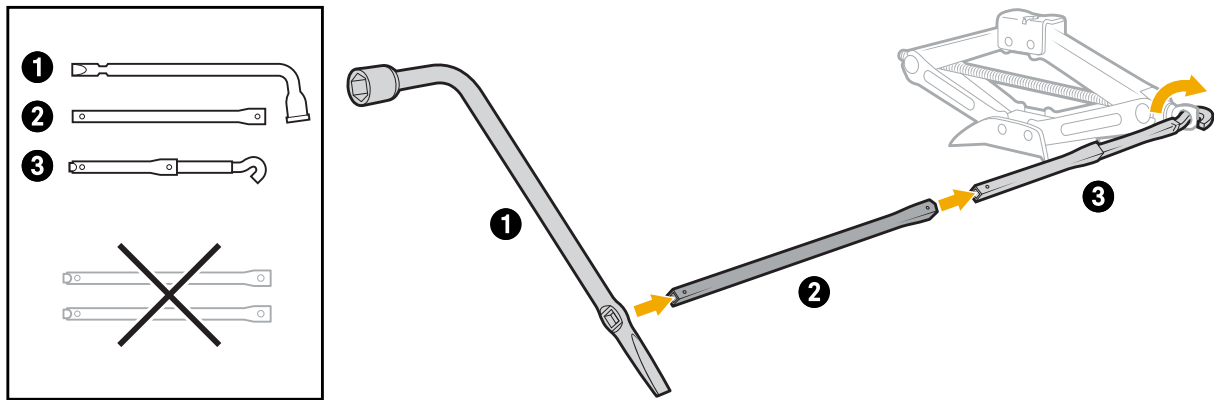

9. Raise the jack slightly to ensure that it's straight and the top of the jack aligns with the jack adapter.

**NOTE**

If the jack begins to tilt, lower the jack, then reposition the jack rearward approximately 2 in (5 cm) and try again.

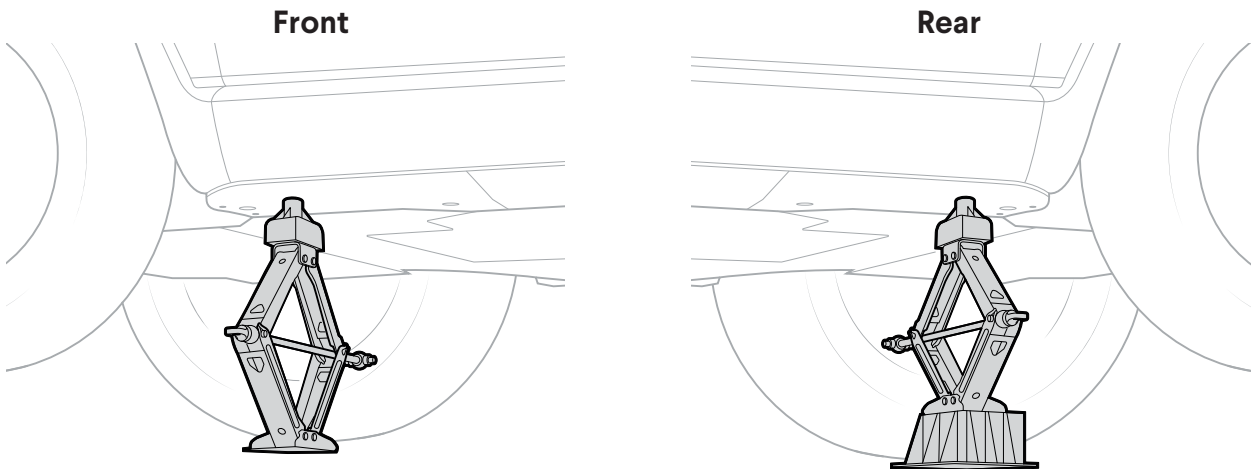

## REMOVE AND REPLACE A WHEEL



**DANGER**

Don't place any part of your body under the vehicle while it's lifted.

### Remove a Wheel

1. Turn on **Tire Change** mode and place the tire jack under the jack point. See [Lift the Vehicle with the Tire Service Kit](#) (page 8).
2. Raise the jack to lift the vehicle slightly, keeping the tire on the ground.
3. Loosen the lug nuts counterclockwise one half-turn with a lug wrench.
4. Raise the jack to lift the vehicle so the tire doesn't touch the ground.
5. Fully loosen and remove the lug nuts.
6. Remove the wheel from the vehicle by gripping the tread of the tire and pulling it straight out.

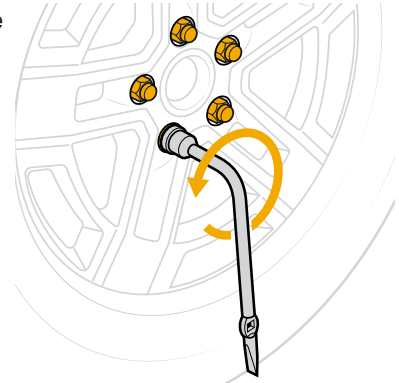

### Install a New Wheel

1. Lift the wheel and align the wheel studs with the holes in the rim.
2. Push the wheel onto the hub.

**NOTE**

Ensure the wheel is fully seated to the hub.

3. Reinstall the lug nuts and tighten them by hand.
4. If you're using the compact spare tire, inflate the tire to the recommended pressure (listed on the Tire and Loading Information label on the driver's door pillar).



**WARNING**

Keep your hands and fingers away from the tire during inflation or deflation to avoid a pinch hazard.

5. Lower the jack until the tire touches the ground but doesn't carry the full weight of the vehicle.

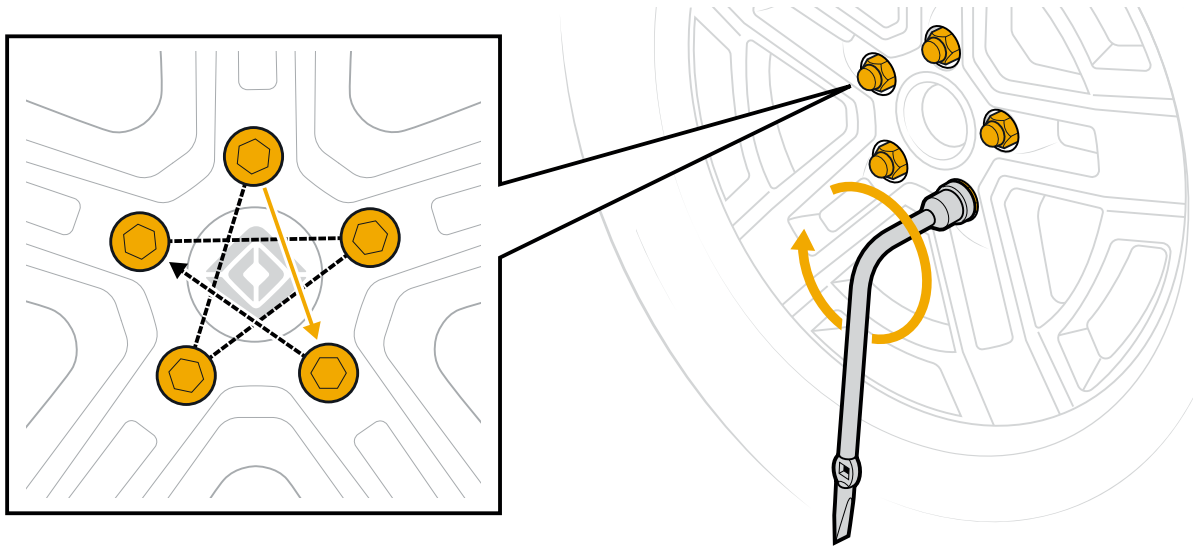

## CHANGE A TIRE

- Torque the lug nuts in an alternating star pattern to 190 N•m. If you don't have a torque tool, tighten until the lug nuts cannot be turned further.



- Lower the jack until the full weight of the vehicle rests on the tires.
- Remove the tire service kit and wheel chocks.
- If you're using the full-size spare tire, swap the wheel center cap.

### Store the Removed Wheel

- Go to **Settings**  in the center display. Choose **Vehicle**. Then choose **Service**. Turn off **Tire Change** mode.
- Lower the vehicle to improve access to the spare tire compartment. Go to **Drive Modes** . Choose **All-Purpose** , and then choose **Standard** under **Ride Height**.
- For R1T, store the removed wheel and the tire service kit in the spare tire compartment in the truck bed.
  - Place the wheel with the outside of the rim facedown.
  - Reinstall the tire service kit retention rod.
  - Replace the tire service kit and secure it with the spare tire wing nut.
- For R1S, store the removed wheel and the tire service kit in the rear cargo area.
  - Place the wheel vertically in the spare tire compartment.
  - Secure the wheel, tire service kit, and any other cargo.
- Choose your previous drive mode and ride height.
- Repair or replace the removed tire once you've reached your destination.

# Lift the Vehicle with a Non-Rivian Jack

Before you lift the vehicle, you must remove the underbody panels if you don't have a Rivian-supplied tire jack or if you need to lift more than one tire.



## CAUTION



Don't place a jack directly on the underbody panels or the vehicle battery.

## PREPARE TO LIFT THE VEHICLE

1. Ensure the vehicle is in **Park**.
2. If you're lifting one tire, secure the vehicle by placing wheel chocks diagonally opposite the tire to be changed.

### NOTE

The electronic park brake is only on the rear wheels.  
If you lift a rear wheel, the vehicle may roll.

3. Go to **Drive Modes**  in the center display. Choose **Off-Road All-Terrain** . Then choose **Highest** under **Ride Height**.
4. Go to **Settings** . Choose **Vehicle**. Then choose **Service**. Turn on **Tire Change** mode.

### NOTE

Automatic suspension adjustments pause with **Tire Change** mode on. You also can't adjust ride height with **Tire Change** mode on.

## LIFT THE VEHICLE WITH A NON-RIVIAN JACK

---

5. Remove the underbody panels to access the frame rails. See [Remove the Front Panels](#) (page 15) and [Remove the Rear Panels](#) (page 16).

### R1T

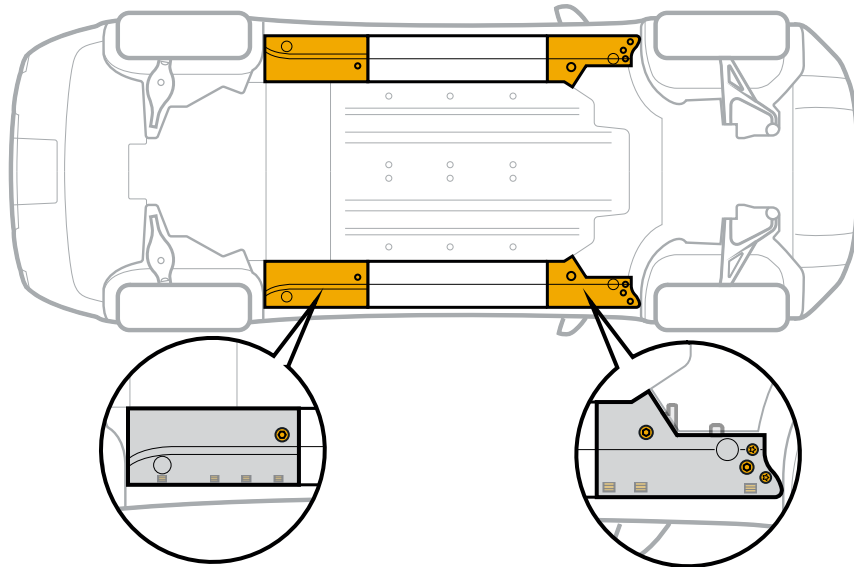

### R1S

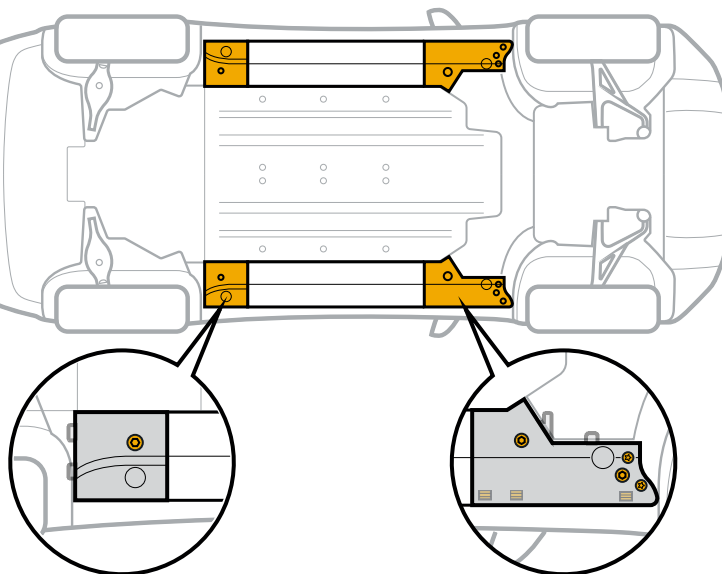

## REMOVE THE FRONT PANELS

1. Remove the four bolts on the front panel.
  - a. Use a T20 Torx screwdriver to remove the two small bolts.
  - b. Use a 10 mm socket to remove the two large bolts.
  - c. Save the bolts for reinstallation.
2. Grab the outer edge of the panel and pull down gently to release the clips.

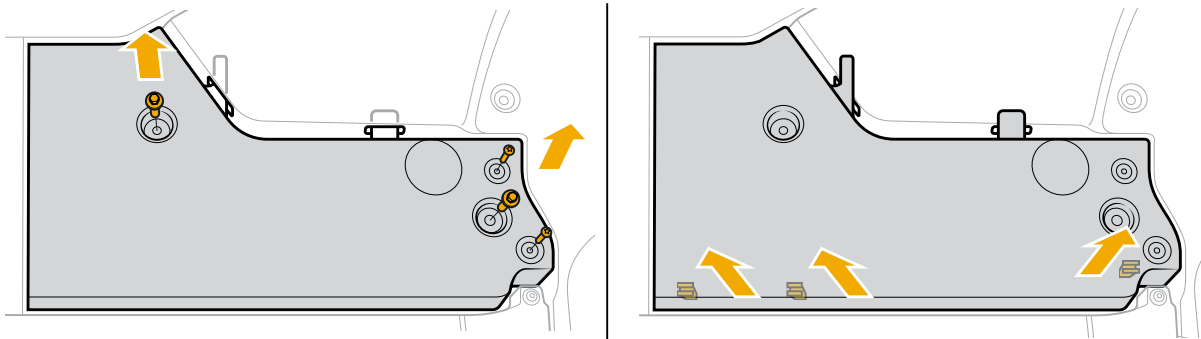

3. Pull down further to remove the panel from the double-sided tape. Save the panel for reinstallation.
4. Repeat for the other front panel as needed.

## REMOVE THE REAR PANELS

1. Use a 10 mm socket to remove one bolt from the rear panel. Save the bolt for reinstallation.
2. Grab the outer edge of the panel and pull down gently to release the clips.

### R1T

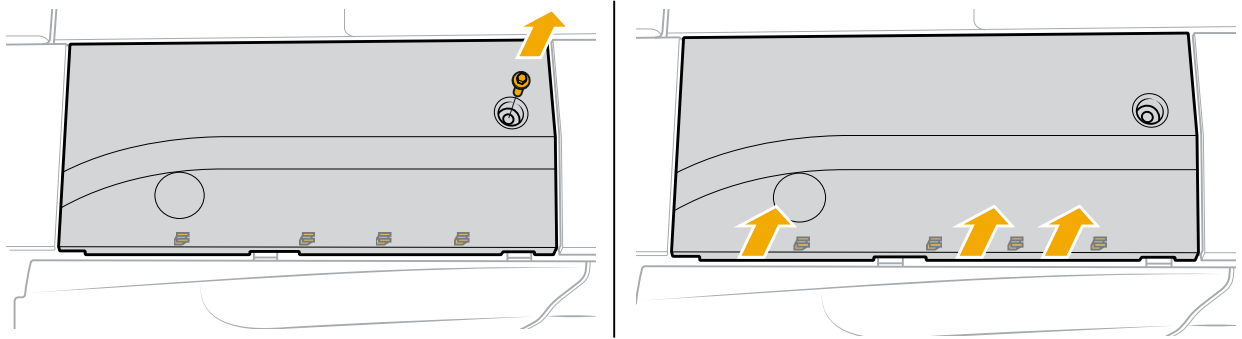

### R1S

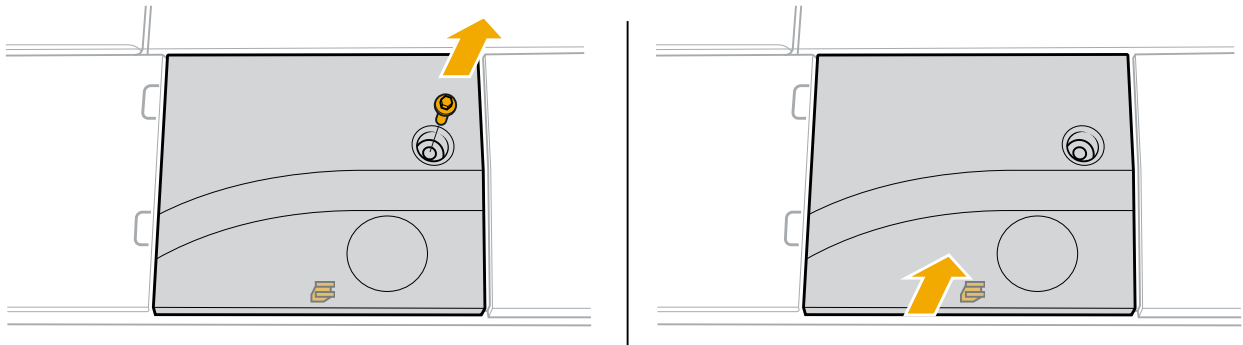

3. Pull down further to remove the panel from the double-sided tape. Save the panel for reinstallation.
4. Repeat for the other rear panel as needed.



## JACK AND LIFT THE VEHICLE

1. Use a jack that is rated to lift at least 3 tons with 23 in (59 cm) of range.
2. Use a rubber pad to protect the underbody finish.
3. Place the jack under the lift point on the frame rail.

### Front

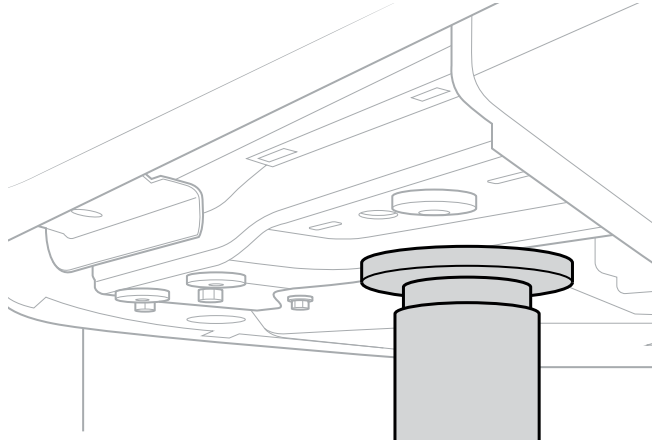

### Rear

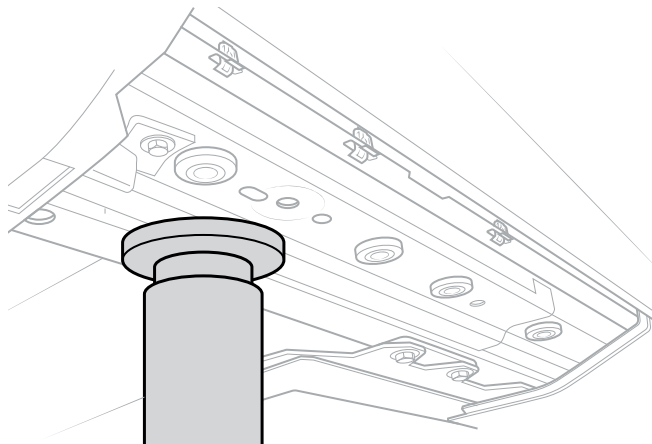

### DANGER

Don't place any part of your body under the vehicle while it's lifted.

4. Follow the instructions included with the jack to raise and lower the vehicle.

## REINSTALL THE PANELS

1. Clean the frame rail surface with an alcohol swab or wipe to ensure the double-sided tape will adhere.
2. Reinstall the panels.
  - a. Align the tabs on the panel to the slots on the vehicle.

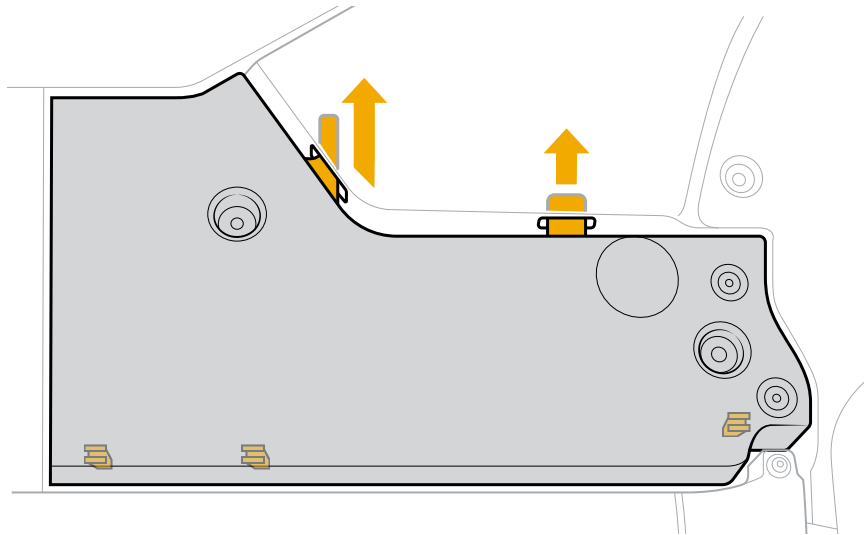

- b. Secure the clips on the panel.

### NOTE

If any clips are broken, [contact Rivian](#) to replace the panel. Secure the panel with the remaining clips and bolts until a replacement is available.

- c. Reinstall the large and small bolts on each front panel.
  - d. Reinstall the bolt on each rear panel.
3. Go to **Settings** ⚙️. Choose **Vehicle**. Then choose **Service**. Turn off **Tire Change** mode.
  4. Choose your previous drive mode and ride height.

# Transport the Vehicle



## CAUTION

Only transport Rivian vehicles on a flatbed tow truck. To prevent damage, don't tow the vehicle behind another vehicle or with two wheels on the ground.

## PREPARE THE VEHICLE FOR TOWING

1. Ensure the front wheels face forward and are parallel with the vehicle.
2. Secure the steering wheel with a holder or strap to keep the wheels straight.



## CAUTION

To prevent damage, don't use j-hooks to connect to any suspension components.

3. Connect the front of the vehicle to the tow truck winch with 6 ft (1.8 m) endless loops or a nylon bridle through the lower control arms.

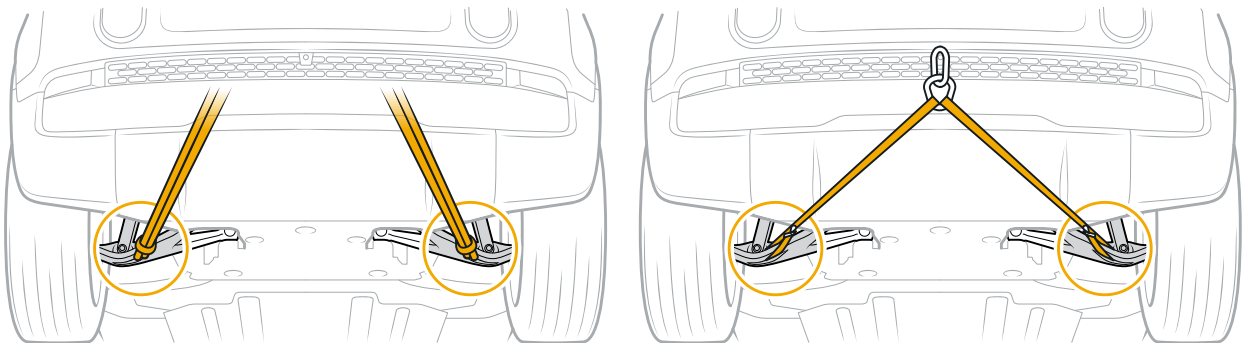

## NOTE

If you can't tow from the front of the vehicle, you can [connect to the trailer hitch](#) (page 21) to tow from the rear.

4. Press and hold the brake pedal.
5. Go to **Settings**  on the center display.
6. Choose **Vehicle**. Then choose **Service**. Turn on **Park brake release**.

## NOTE

Park brake release turns off after 15 minutes. You can also turn it off by putting the vehicle in **Park** or turning off **Park brake release** in the center display.

7. Release the brake pedal and confirm release of the electronic park brake.

You can now [load the vehicle](#) (page 24) onto the tow truck.

**NOTE**

If you can't release the electronic park brake, you need to [lift the rear wheels](#) (page 22) to load the vehicle onto the tow truck.

## CONNECT TO THE TRAILER HITCH

Connect to the trailer hitch when you can't tow from the front of the vehicle.

1. Ensure the front wheels face forward and are parallel with the vehicle.
2. Secure the steering wheel with a holder or strap to keep the wheels straight.
3. Remove the trailer hitch cover.
  - a. Use a flathead screwdriver to loosen the two captive screws. Turn a quarter turn counterclockwise.
  - b. Grip the cover and pull straight down.
4. Insert a nylon bridle or short endless loops through the trailer hitch (1).

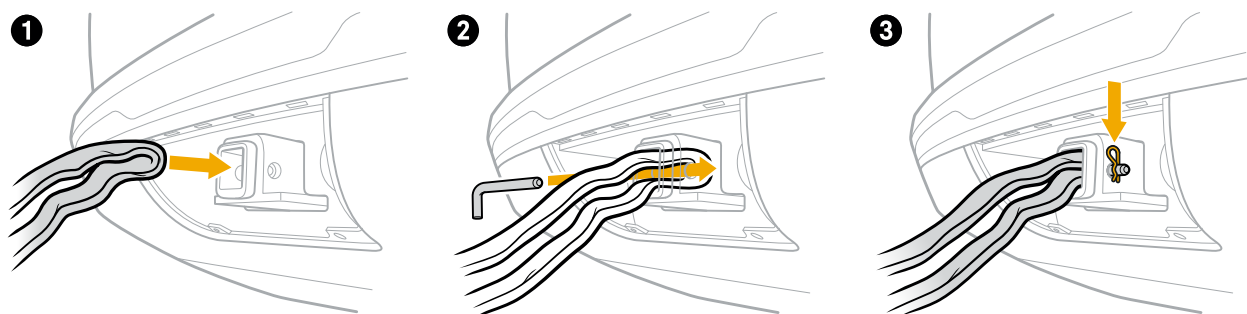

5. Insert the tow pin through the hitch to connect the bridle or loops (2), and then install the tow pin retaining clip (3).
6. Press and hold the brake pedal.
7. Go to **Settings**  on the center display.
8. Choose **Vehicle**. Then choose **Service**. Turn on **Park brake release**.

### NOTE

Park brake release turns off after 15 minutes. You can also turn it off by putting the vehicle in **Park** or turning off **Park brake release** in the center display.

9. Release the brake pedal and confirm release of the electronic park brake.

You can now [load the vehicle](#) (page 24) onto the tow truck.

### NOTE

If you can't release the electronic park brake, you need to [lift the rear wheels](#) (page 22) to load the vehicle onto the tow truck.

## LIFT THE REAR WHEELS

If the battery is dead or you can't release the electronic park brake, lift the rear wheels to load the vehicle onto a tow truck.



### DANGER

Secure the vehicle and connect it to the tow truck before you lift the rear wheels. The vehicle can roll when you lift the rear wheels.



### CAUTION

Only lift the rear wheels to load the vehicle onto the tow truck. Don't tow the vehicle behind another vehicle or with two wheels on the ground.

1. Chock the front wheels to secure the vehicle.
2. Connect the vehicle to the tow truck using an endless loop through the front control arms or rear trailer hitch.
3. Lift the rear wheels using skates, a dolly, or a tow truck wheel lift.

### R1T

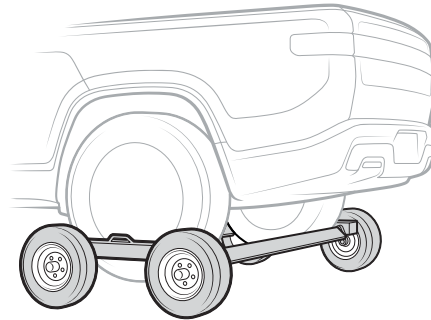
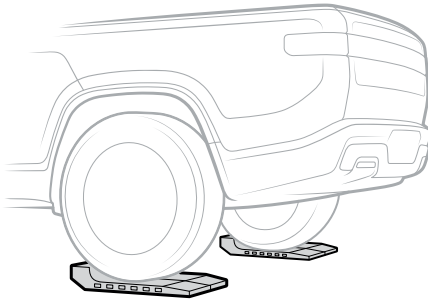

### R1S

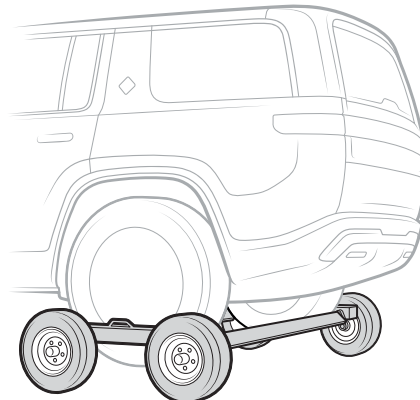
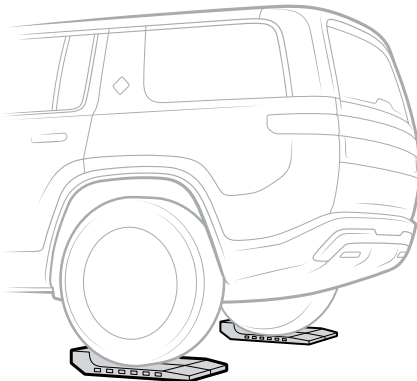

4. With the rear wheels off the ground, position the vehicle to be loaded onto the tow truck bed.

You can now [load the vehicle](#) (page 24) onto the tow truck.

**NOTE**

If using skates, use the skates to pull the vehicle all the way up the tow truck ramp.

## LOAD THE VEHICLE ONTO THE TOW TRUCK

After you've connected the vehicle, you can load the vehicle onto a flatbed tow truck as follows:

1. Ensure the **Park brake release** is turned on or the rear wheels are lifted. See [Prepare the Vehicle for Towing](#) (page 19).
2. Remove the wheel chocks, if needed.
3. Use the tow truck winch to pull the vehicle onto the tow truck bed.
4. Pull at 5 mph (8 km/h) or less to prevent damage to the drivetrain.

### NOTE

If you pull too fast, the vehicle stops and shifts to **Park**.

### R1T

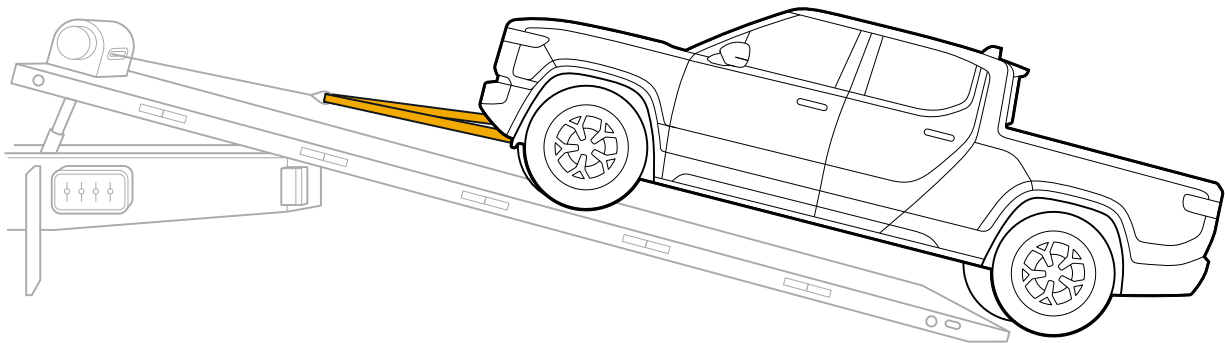

### R1S

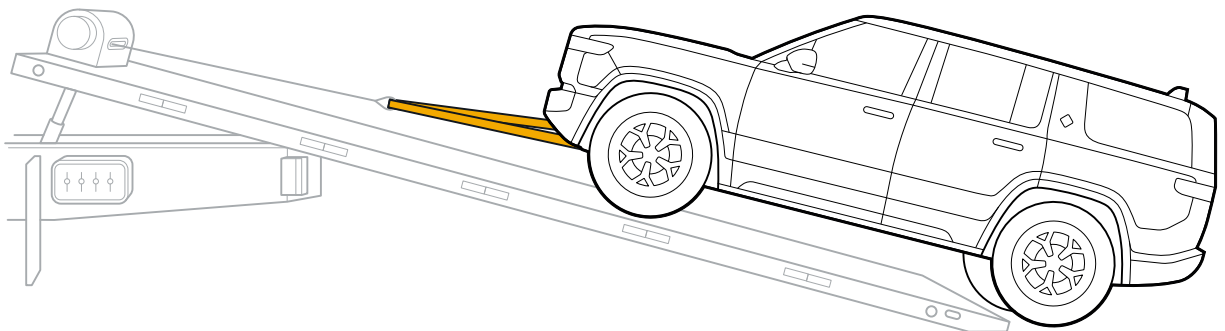



5. Tie down the vehicle using eight-point retention straps with two points of contact per corner.

**R1T**

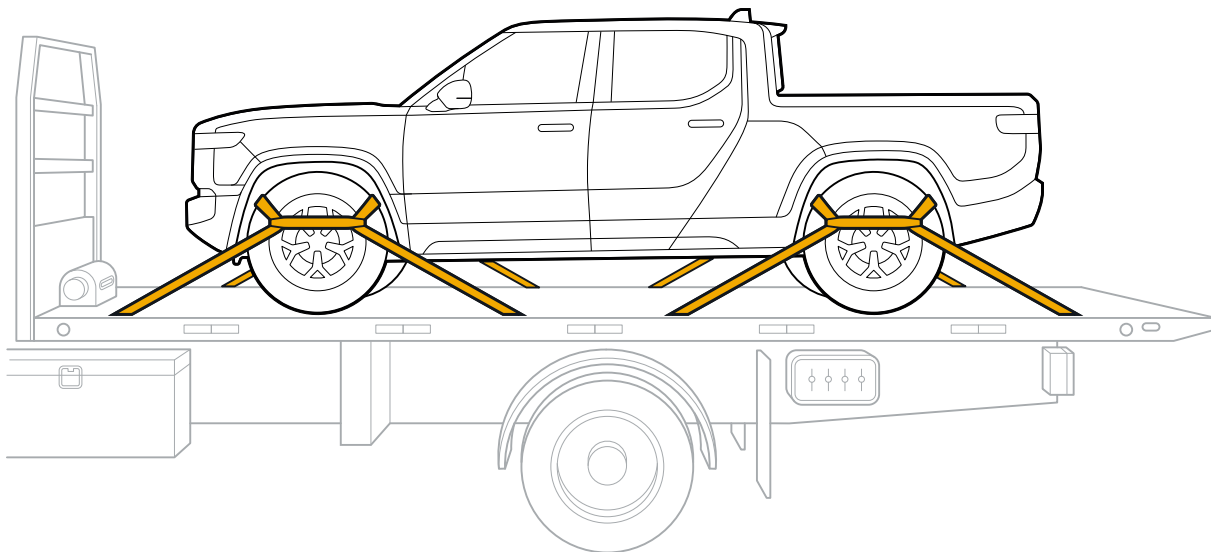

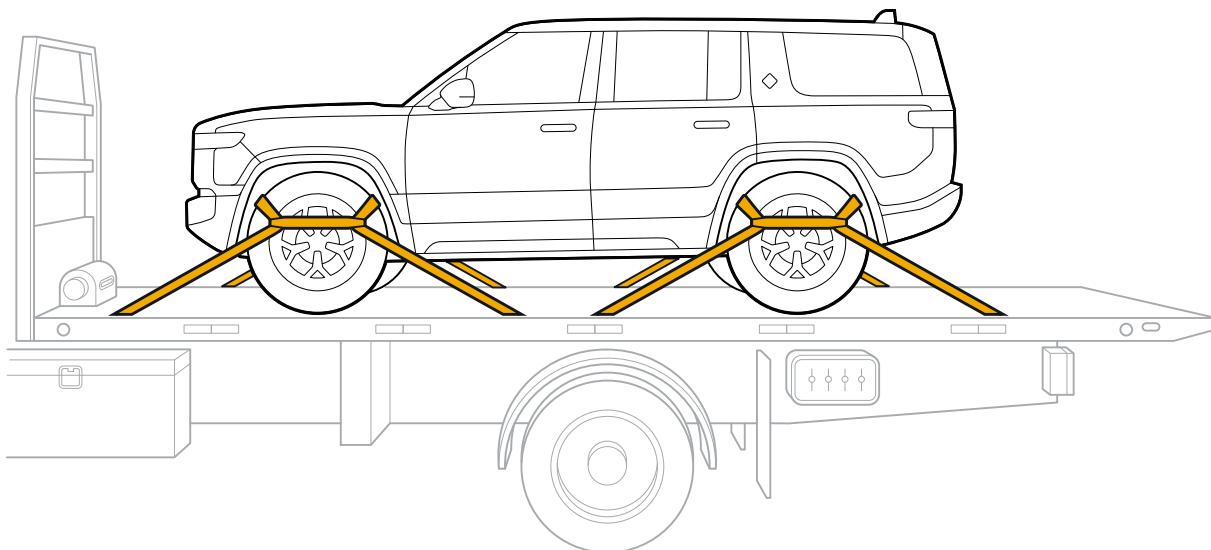

**R1S**



**CAUTION**

To prevent damage, ensure the straps don't contact the brake lines or suspension components behind the tire.

6. Put the vehicle into **Park**.
7. Go to **Drive Modes**  in the center display. Choose **Conserve** . Then choose the **Lowest** ride height.
8. If you're transporting the vehicle over 50 mi (80 km), turn on [Vehicle Shipping Mode](#) (page 26) to preserve battery charge.

## VEHICLE SHIPPING MODE



Use Vehicle Shipping mode to preserve battery charge while the vehicle is in transit. Vehicle Shipping mode turns off various features, including the following:

- Software updates
- Gear Guard alarm
- Passive lock/unlock

### NOTE

When Vehicle Shipping mode is turned on, you can leave keys inside the vehicle and the vehicle sleeps normally.

To turn on Vehicle Shipping mode when you are ready to transport the vehicle:

1. Go to **Drive Modes**  in the center display. Choose **Conserve** . Then choose the **Lowest** ride height.
2. Put the vehicle into **Park**.
3. Go to **Settings** . Choose **Vehicle**. Then choose **Service**.
4. Turn on **Vehicle Shipping** mode.

### NOTE

Startup may take longer than normal when Vehicle Shipping mode is turned on.

To turn off Vehicle Shipping mode after you arrive at your destination:

1. Put the vehicle in **Park**.
2. Go to **Settings**  in the center display. Choose **Vehicle**. Then choose **Service**.
3. Turn off **Vehicle Shipping** mode.

# Manually Open the Hood

Follow these steps if the hood won't open normally:

1. Use a Torx (star) screwdriver with T20 and T25 bits to remove the screws from the inboard side of the left front wheel liner.

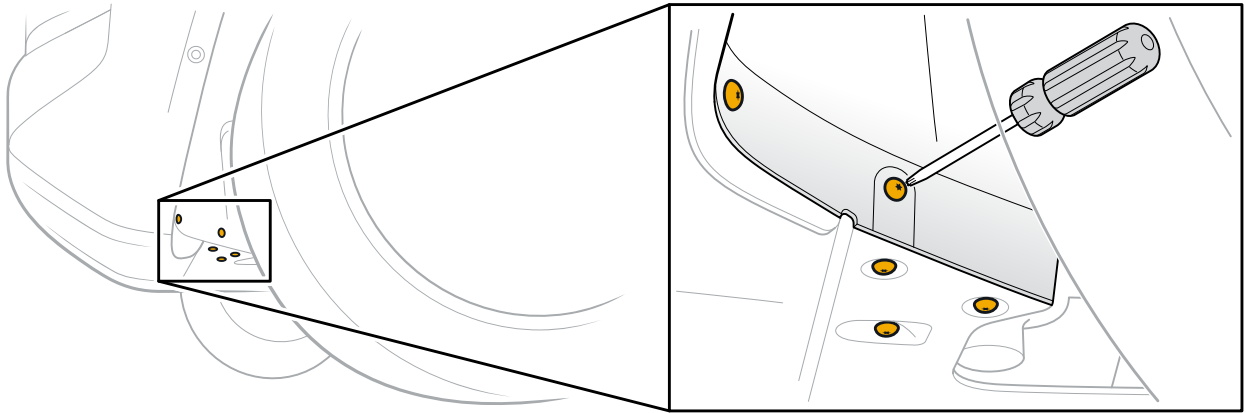

2. Lower the front skid plate to access the hood release cable.

## NOTE

Remove extra screws as needed to improve access to the area.

3. Reach in and up to locate the hood release cable. Pull the cable to release the hood latch.

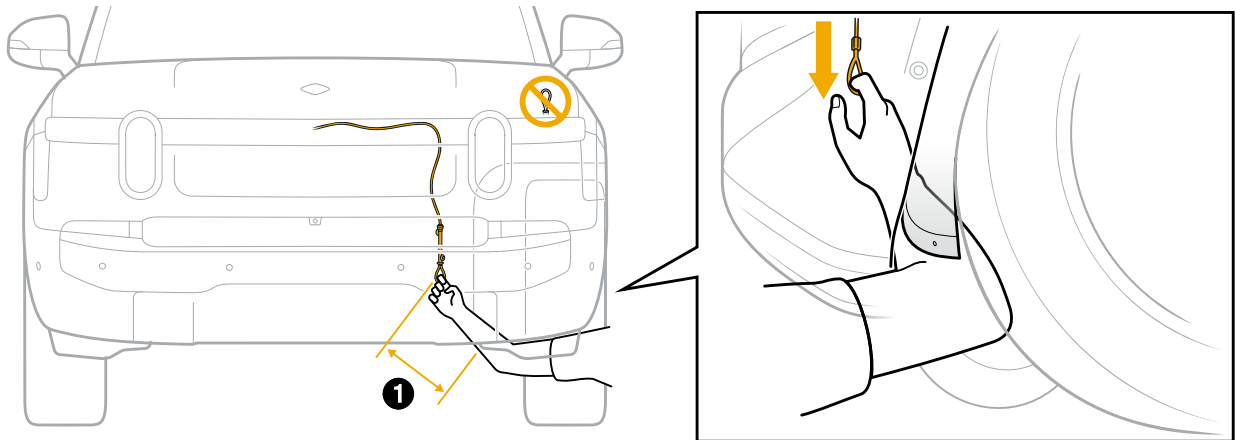

Item	Reach Distance (Approximate)
1	11 in (28 cm)

## MANUALLY OPEN THE HOOD

---

4. If the latch doesn't release, have a second person gently lift up and push down on the hood while you pull on the cable.

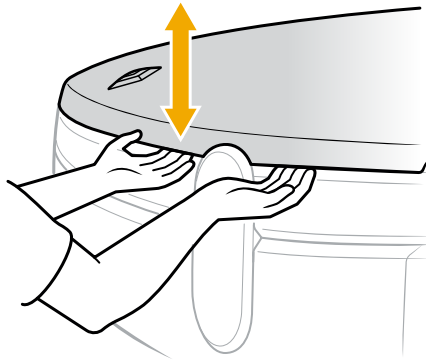

5. Replace the screws after the hood opens.

# Manually Release the Charge Plug

If the charge plug won't release from the charge port, you can manually release it.

## NOTES

- Always stop a charge session before you unplug from a DC fast charger. Go to **Energy** in the center display, and then choose **Stop Charging**.
- Ensure the vehicle is unlocked before you unplug from an AC charger.

1. Open the vehicle hood.
2. Remove the trim panel from the driver side of the vehicle. Pull up gently to release the clips.

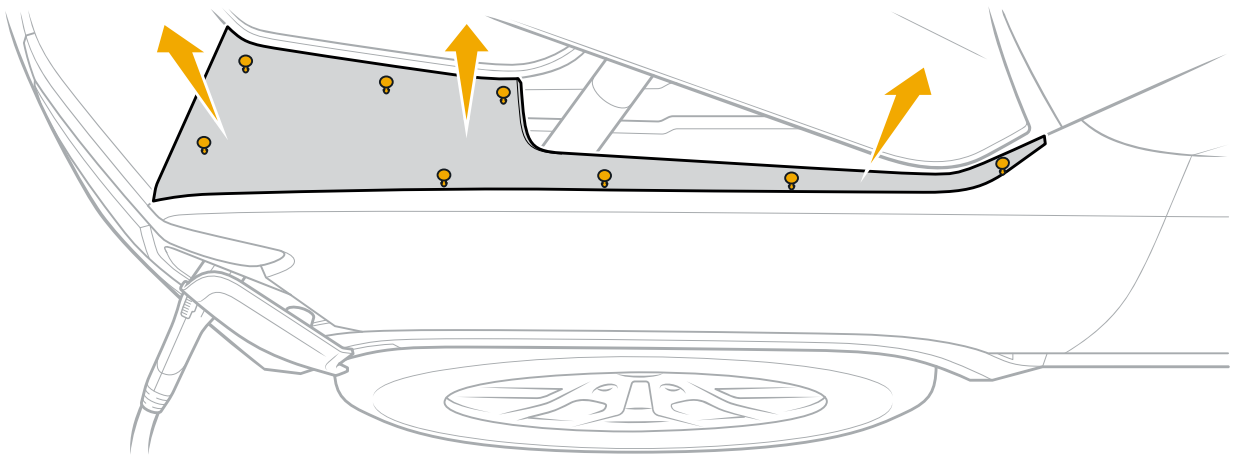

3. Gently pull the cable to release the charge plug.
4. Remove the charge plug from the charge port.
5. Replace the trim panel and secure the clips.
6. Close the hood.

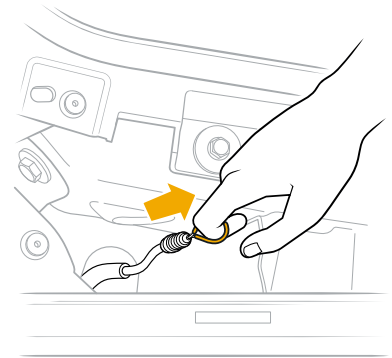

# Jump-Start the 12 V Batteries

The vehicle has two 12 V batteries under the hood. Signs of discharged 12 V batteries include the following:

- The doors and storage areas don't unlock.
- The vehicle doesn't respond to the key fob.
- The lighting doesn't illuminate.
- The displays don't turn on.



## **DANGER**

Never allow the jump cables to touch each other or any metal part of the vehicle.



## **CAUTION**

Don't use a Rivian vehicle to jump-start another vehicle.

## **IMPORTANT**

A successful 12 V battery jump start lets you open the doors and front trunk. It also lets you open the charge port door if you need to charge the high-voltage battery.

If the high-voltage battery state of charge is zero, a jump start allows you to release the electronic park brake to [transport the vehicle](#) (page 19).

## JUMP-START THE PRIMARY 12 V BATTERY

Before you begin, ensure that you have an adequate power source to jump-start a Rivian vehicle.

- If you're using a tow truck to jump-start, the tow truck must run until the Rivian vehicle powers up.
- If you're using a jump box, the jump box must maintain a steady voltage between 13 V and 16 V at 30 A.

To jump-start the primary 12 V battery:

1. Remove the trailer hitch cover to access the jump-start wire harness.
2. Remove the round access panel to the right of the trailer hitch.
3. Pull out the jump-start wire harness and remove the protective tape from the connectors.

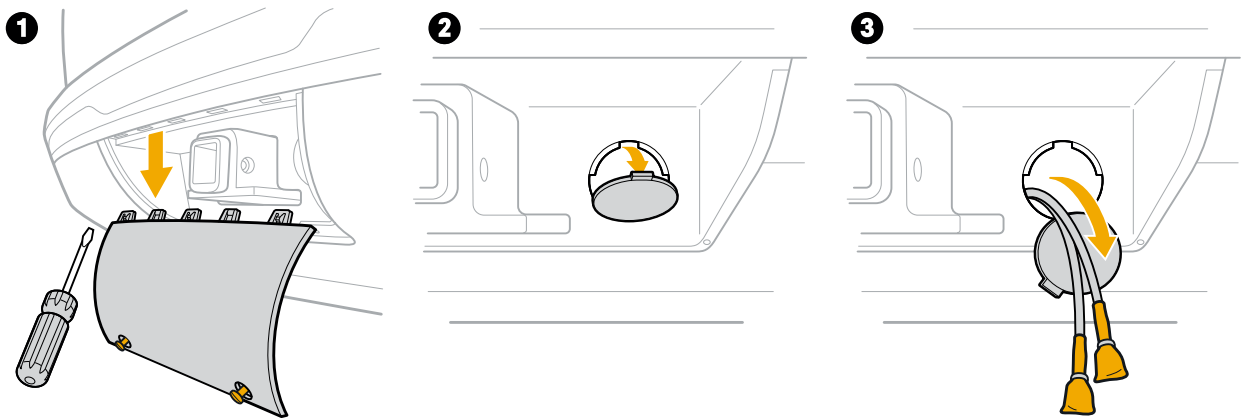

4. Connect the red positive lead (+) to the red lead on the jump-start wire harness.
5. Connect the black negative lead (-) to the black lead on the jump-start wire harness.

When the primary 12 V battery has enough power, you can unlock the vehicle to open the doors, front trunk, and charge port door.

You can release the electronic park brake from the center display if needed to [transport the vehicle](#) (page 19) to a Rivian Service Center.

If the high-voltage battery state of charge is zero and you're close enough to a charger:

1. Open the charge port door.
2. Plug in to the charger.
3. If needed, turn off the charge schedule in the **Energy** app on the center display.
4. Allow the vehicle to charge until the high-voltage battery reaches 25% state of charge.
5. [Restart the vehicle](#) (page 35).

# JUMP-START THE SECONDARY 12 V BATTERY

If the vehicle lights don't work normally or you can't put the vehicle in Drive after you [jump-start the primary 12 V battery](#), you may need to jump-start the secondary 12 V battery.

Before you begin, ensure that you have an adequate power source to jump-start a Rivian vehicle.

- If using a tow truck to jump-start, the tow truck needs to run until the Rivian vehicle powers up.
- If using a jump box, it needs to maintain a steady voltage between 13 V and 16 V at 30 A.
- If you have two jump boxes, you can continue to charge the primary 12 V battery at the same time.

To jump-start the secondary 12 V battery:

1. Open the hood.
2. Remove the air intake cover by gently pulling up to release the clips.
3. Remove the air intake duct to access the 12 V batteries.

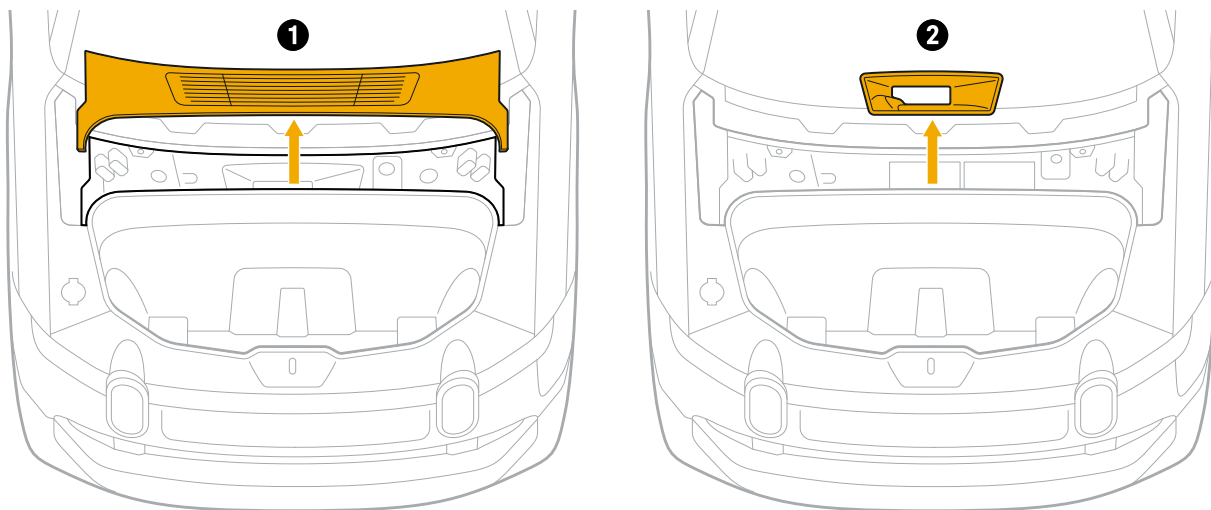



## JUMP-START THE 12 V BATTERIES

---

4. Remove the red cover from the secondary 12 V battery (closest to passenger side).

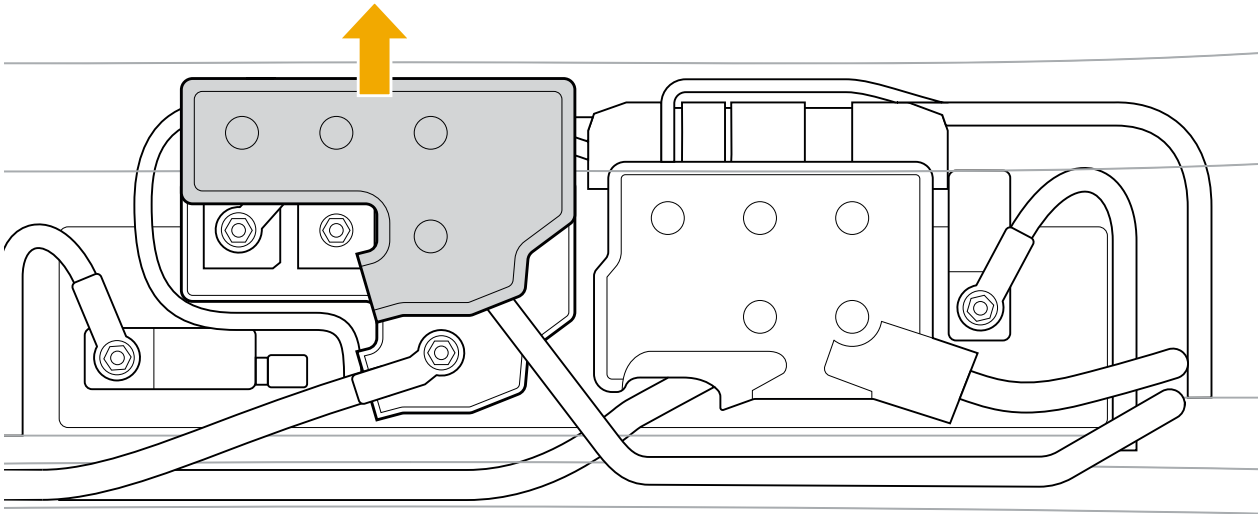

5. Connect the red positive (+) lead to one of the positive (+) terminals on the secondary battery.

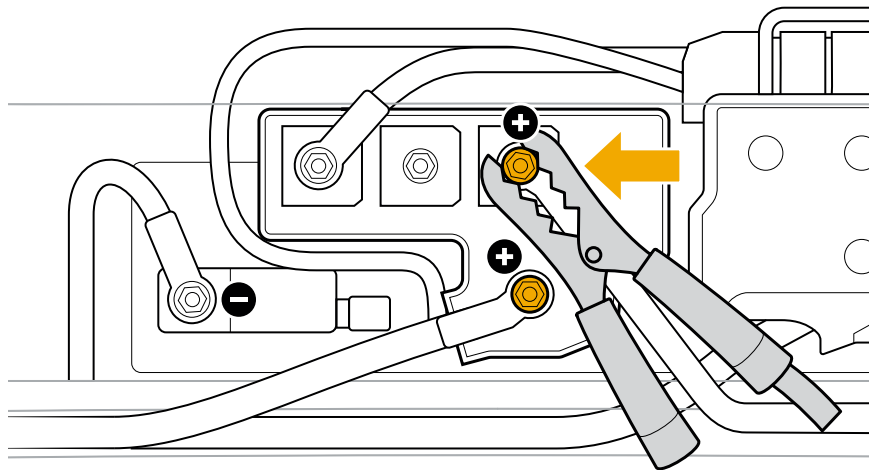

## JUMP-START THE 12 V BATTERIES

---

6. Connect the black negative (-) lead to the negative (-) terminal on the secondary battery.

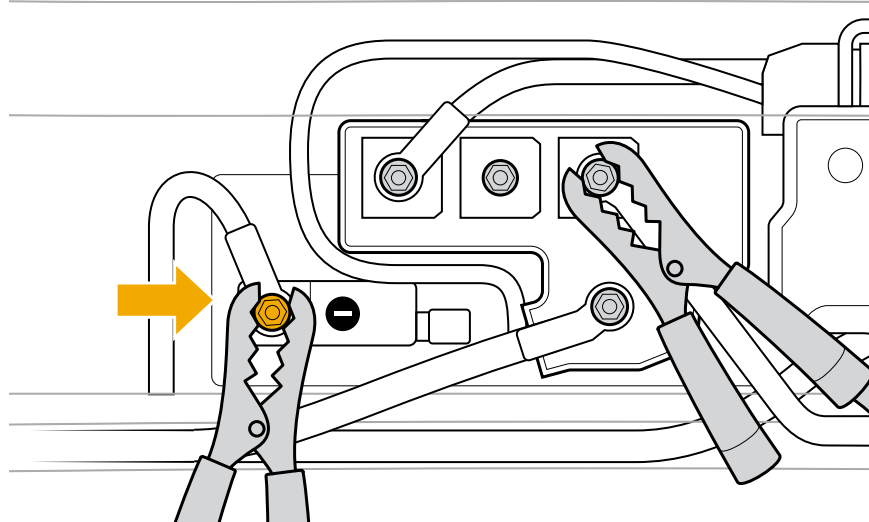

7. Allow the secondary battery to charge to a sufficient level. If you have a voltmeter, ensure the battery is charged to at least 5 V.
8. If you are plugged in to a vehicle charger, charge until the high-voltage battery reaches 25% state of charge.
9. [Restart the vehicle](#) (page 35).

If you can't restart or drive the vehicle, [transport the vehicle](#) (page 19) to a Rivian Service Center.

If the windows don't fully express close or they need calibration, [reset the windows](#) (page 37).

# Perform a Restart

## RESTART THE SOFTWARE

If the vehicle apps, connectivity, or displays do not work normally, you may need to restart the software.

1. Ensure the vehicle is in **Park**.
2. Find the two outermost control buttons on the steering wheel.
3. Press both buttons at the same time and hold for 15 seconds.

### NOTE

The displays go dark for about one minute until the restart is complete.

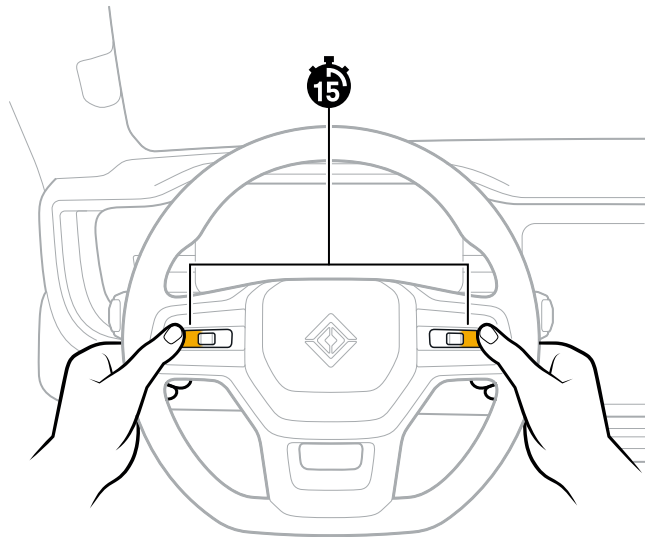

## RESTART THE VEHICLE



**CAUTION**

[Contact Rivian](#) before you restart the vehicle.

If the vehicle does not work normally after you restart the software, you may need to restart the vehicle.

1. Ensure the vehicle is in **Park** and not plugged in.
2. Find the left thumb control button on the steering wheel and the hazard lights button on the overhead console.
3. Press both buttons at the same time and hold for 15 seconds.

**NOTE**

The displays go dark, and then a progress indicator lets you know when the restart is complete.

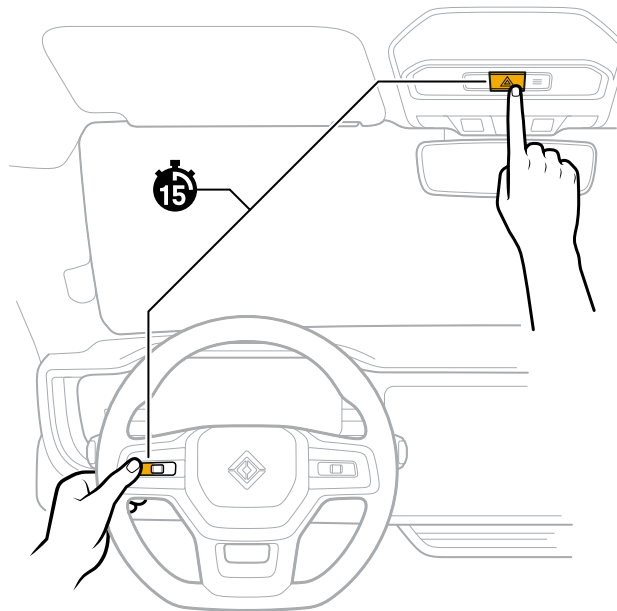

# Reset the Windows

If the windows don't fully express close or you get an error that says they need calibration, reset the windows.

1. If needed, unlock the passenger windows from **Access and Security** on the center display.
2. Lower the window until it completely opens.
3. Continue to hold the window switch down for five seconds.
4. Raise the window until it completely closes. If the window stops on the way up, return to step 2.
5. Continue to hold the window switch up for five seconds.
6. Ensure that express close works from the window switch.
7. Repeat steps 2-6 for each window that needs calibration.

# Disable the High-Voltage System

Disable the high-voltage system for safety, such as before a service procedure or after a major collision.

1. Open the hood.
2. Remove the air intake cover by gently pulling up to release the clips.
3. Remove the air intake duct to access the red high-voltage disconnect loop and the 12 V batteries.

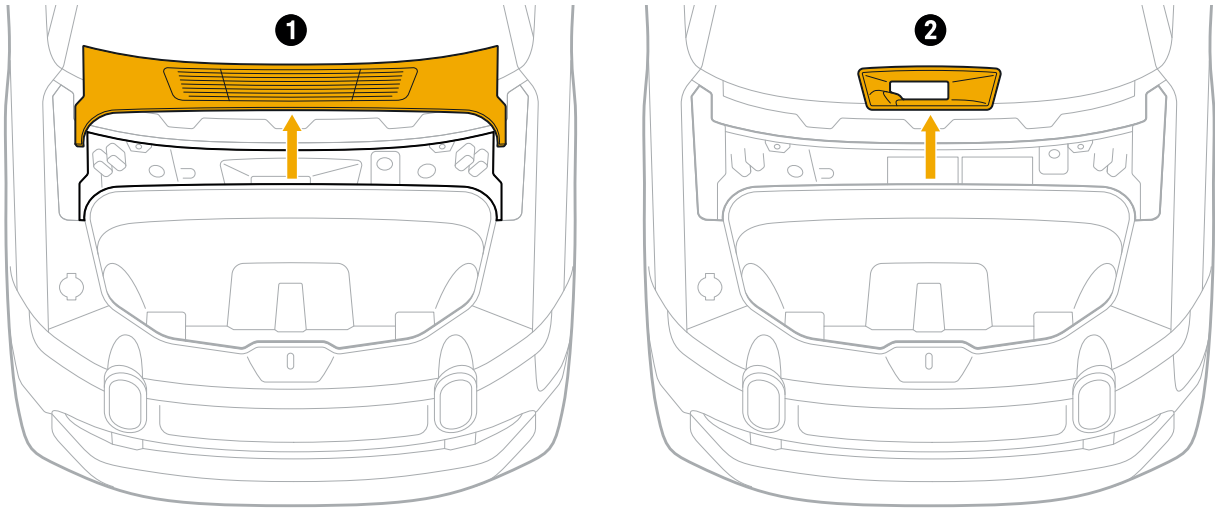

4. Remove the red high-voltage disconnect loop. Push the tab to unlock the connector and pull to remove.

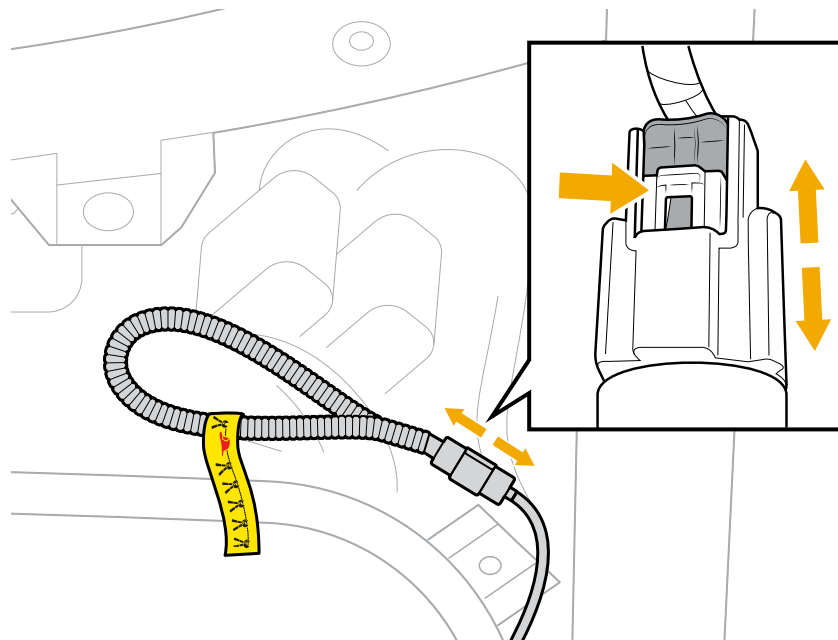

## DISABLE THE HIGH-VOLTAGE SYSTEM

---

5. Use a 10 mm socket wrench to disconnect both 12 V battery negative terminals.

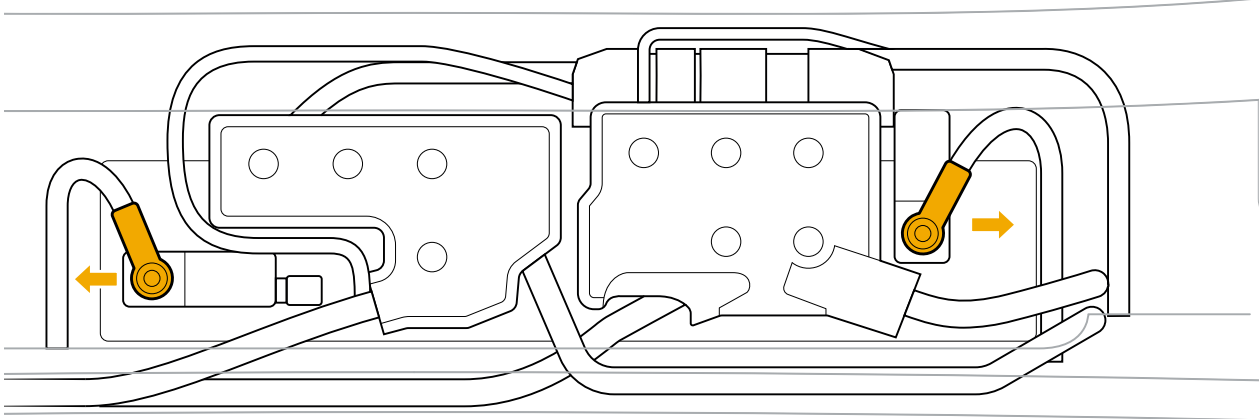

The high-voltage battery contactors are now open and the high-voltage system is disabled. The 12 V batteries are no longer supported.

# Customer Service

Still need help? Connect with us.



## Customer Engagement Center

---

(888) RIVIAN1 / (888) 748-4261  
[customerservice@rivian.com](mailto:customerservice@rivian.com)  
[rivian.com/support](https://rivian.com/support) Support Center and Chat

## Insurance

---

(888) RIVIAN8 / (888) 748-4268

## Roadside Assistance 24/7

---

(844) RIVIAN4 / (844) 748-4264

## Service 24/7

---

(855) RIVIAN5 / (855) 748-4265