

WALL CHARGER

Installation Guide

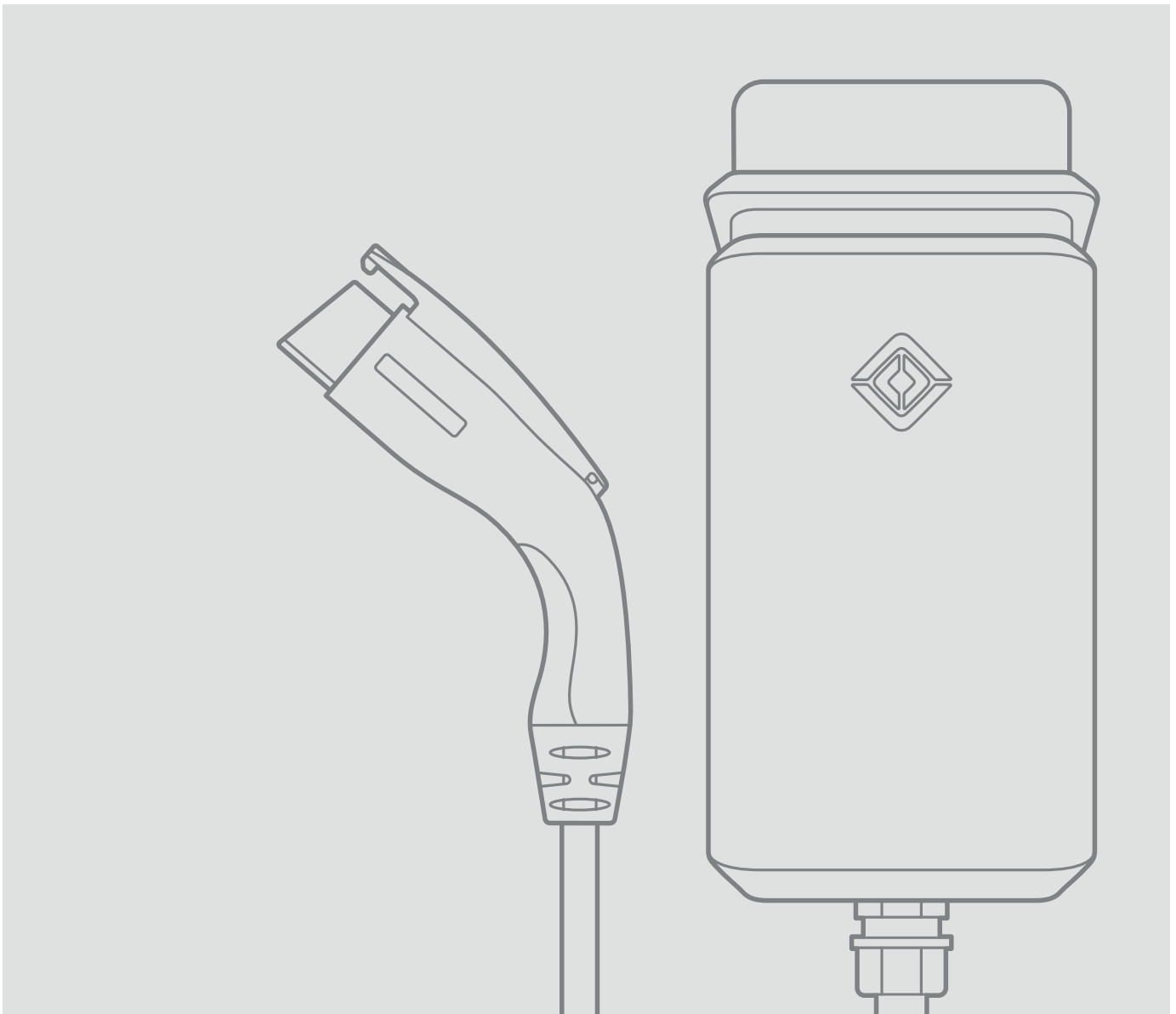



© 2021-2022 Rivian Automotive, LLC. All rights reserved.

All information in this document and all Rivian software is subject to copyright and other intellectual property rights of Rivian Automotive, LLC, its affiliates, or its licensors. This material may not be modified, reproduced, or copied, in whole or in part, without the prior written permission of Rivian Automotive, LLC, its affiliates, or its licensors. Unless indicated otherwise, all trademarks are owned and registered by Rivian Automotive, LLC, its affiliates, or its licensors in the United States and/or other countries. Please visit <https://www.rivian.com/legal/brand> for Rivian's trademarks and service marks.

Contents

| | |
|---------------------------------------------------------------------|-----------|
| IMPORTANT SAFETY INSTRUCTIONS | 4 |
| SAVE THESE INSTRUCTIONS | 4 |
| Precautions | 4 |
| Risk of Electrical Shock | 4 |
| Risk of Personal Injury | 5 |
| Risk of Damage to Equipment | 5 |
| Safety Symbols on Hardware Labels | 6 |
| Introduction | 7 |
| Identify Parts | 7 |
| Tools | 8 |
| Remove the Faceplate | 8 |
| Installation | 9 |
| Select an Installation Location | 9 |
| Attach the Mounting Plate | 10 |
| Attach the Wall Charger to the Mounting Plate | 12 |
| Set the Operating Current | 15 |
| Connect Conductors | 16 |
| Install the Faceplate | 17 |
| Wrap and Dock the Cable | 18 |
| Connect to Wi-Fi | 19 |
| What You Need | 19 |
| Connect to the Wall Charger | 19 |
| Light Bar States | 20 |
| Troubleshooting | 20 |
| Power Off the Wall Charger | 21 |
| Remove the Wall Charger | 21 |
| Specifications | 23 |
| Supplemental Information for Electrical Service Wiring | 24 |
| 240V Split-Phase System | 24 |
| FCC Interference Statement | 25 |
| RF Exposure Information | 25 |
| Industry Canada Statement | 25 |
| Radiation Exposure Statement | 25 |
| Customer Service | 26 |

IMPORTANT SAFETY INSTRUCTIONS

SAVE THESE INSTRUCTIONS



DANGER

Read all the instructions before installing the Rivian Wall Charger. Follow the safety instructions and warnings in this guide when installing the Wall Charger. Failure to do so may result in fire, electrical shock, serious injury, or death.

PRECAUTIONS

The following safety symbols are used in this document.



DANGER

Risk of electric shock



DANGER

Risk of personal injury



CAUTION

Risk of damage to equipment

Risk of Electrical Shock



DANGER

- Improper connection of the equipment grounding conductor can result in a risk of electric shock. Check with a qualified electrician or service person if you are in doubt as to whether the product is properly grounded.
- Do not touch live electrical parts. Incorrect connections may cause electric shock.
- No user serviceable parts inside. Refer servicing to qualified service personnel.
- Do not put fingers into the coupler.
- Do not use this equipment if the flexible power cord or cable is frayed, has broken insulation, or any other signs of damage.
- Do not use this equipment if the enclosure or the coupler is broken, cracked, open, or shows any other indication of damage.
- Do not allow unsupervised children in the area during installation of the Wall Charger.
- Before connecting the Wall Charger to a power supply, check that the power supply voltage and current rating corresponds with the power supply details shown on the product rating label.
- Use appropriate protection when connecting to a main switchboard.



- Ground the Wall Charger through a permanent wiring system using the equipment grounding conductor.
- To reduce the risk of fire, connect only to a circuit provided with no more than 60 amperes maximum branch circuit over-current protection in accordance with the National Electrical Code, ANSI/NFPA 70, and the Canadian Electrical Code, Part I, C22.2.
- When a breaker smaller than 60 amperes is used, ensure that the conductor sizes used comply with the minimum sizes prescribed by national and local electrical codes and standards.

Risk of Personal Injury



DANGER

- Disconnect the power supply before installing or repairing the Wall Charger. Failure to do so may result in physical injury or damage to the power supply system and the Wall Charger.
- Keep any packing materials away from children. These materials are a potential source of danger, and can cause suffocation.
- Only a licensed electrician should perform this installation in accordance with the provisions of national electrical codes and standards.

Risk of Damage to Equipment









CAUTION

- Use anti-static gloves, wrist bands connected to ground, and insulated tools for installation and removal of the faceplate.
- Do not operate this equipment in temperatures outside its operating range of -22°F to +122°F (-30°C to +50°C).
- Store this equipment in a clean dry location between -40°F to +176°F (-40°C and +80°C).
- Do not use extender cables to increase the length of the charging cable.
- If this unit is installed outdoors, the components and fittings must be rated for outdoor installation. The outlet must be installed properly to maintain the proper NEMA rating of the enclosure.
- Avoid direct hand contact with components on the network board.
- For storage/shipping of the front panel or network board, use a bubble wrap bag with ESD (electrostatic discharge) protection.
- Rivian does not recommend using a GFCI breaker since the Wall Charger has charging circuit interrupting device (CCID20) protection. Using a GFCI breaker in the panel can cause nuisance tripping. If local codes require a GFCI breaker for plug-in installation, Rivian recommends a hardwire installation.

SAFETY SYMBOLS ON HARDWARE LABELS

The following safety symbols may appear on labels located on hardware used in this installation.

| | |
|-------------------------------------------------------------------------------------|------------------------|
|  | Risk of Electric Shock |
|  | Danger |
|  | Phase |
|  | Equipment Ground |
|  | Instruction Manual |
|  | UL Logo |

Introduction

This document provides installation instructions for the Rivian Wall Charger. It also includes instructions on how to connect the Wall Charger to *WiFi*® and to a Rivian account.

Identify Parts

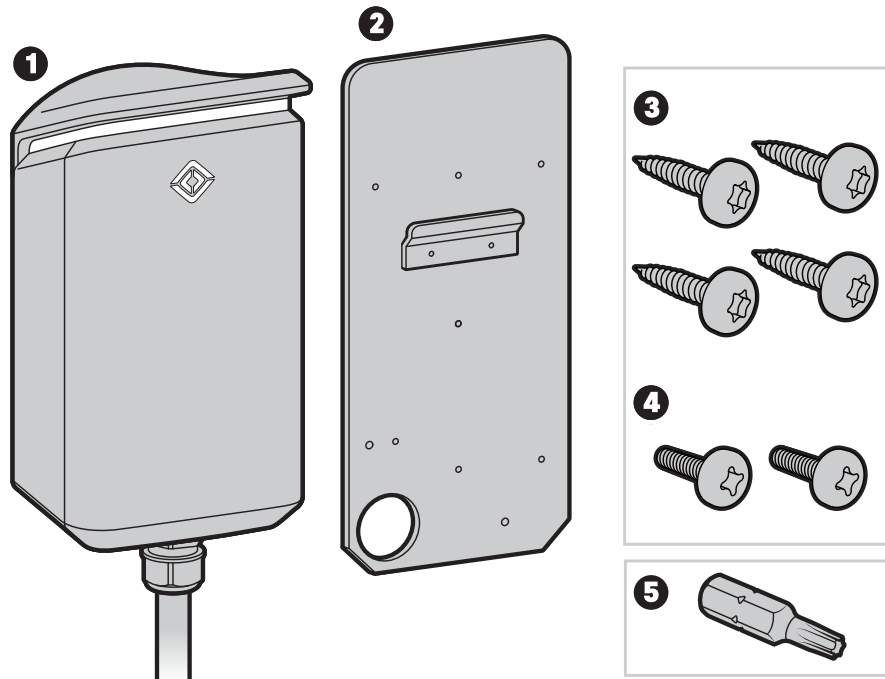

1. Wall Charger
2. Mounting plate
3. Four T20 anchor screws (to attach the mounting plate to a wall)
4. Two 13 mm M4 Phillips screws (to attach the charger to the mounting plate)
5. T20 Security bit

Tools

| Required | Optional |
|-------------------------------------------------------------------------|-------------|
| #2 Phillips screwdriver | Hole saw |
| Security T20 Torx screwdriver | Stud finder |
| Flathead screwdriver, 7/32 in (5.5 mm) width | Level |
| Adjustable torque screwdriver, 10 in-lb (1.1 N·m) to 40 in-lb (4.5 N·m) | |
| Multimeter | |

Remove the Faceplate



CAUTION

- Use anti-static gloves, wrist bands connected to ground, and insulated tools for installation and removal of the faceplate.
- Avoid direct hand contact with components on the network board.

1. Remove the two Security T20 Torx screws on the bottom of the Wall Charger.

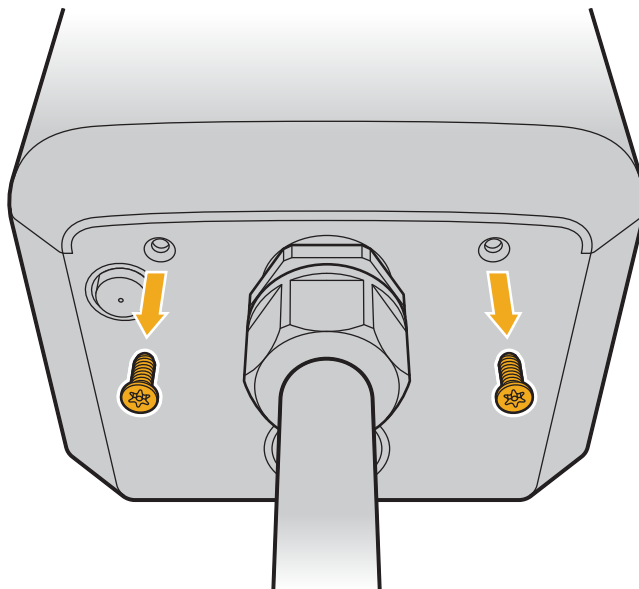

2. Push the faceplate up and remove it.

Installation

SELECT AN INSTALLATION LOCATION



CAUTION

- For indoor installations, install the Wall Charger at least 18 in (46 cm) from the ground to bottom of charger.
- For outdoor installations, install the Wall Charger at least 24 in (61 cm) from the ground to bottom of charger.

For ease of use, install the Wall Charger around chest height, within easy cable reach of the vehicle charge port, and with at least 12 in (30.5 cm) of clearance on the right side to accommodate coupler docking and cable management.

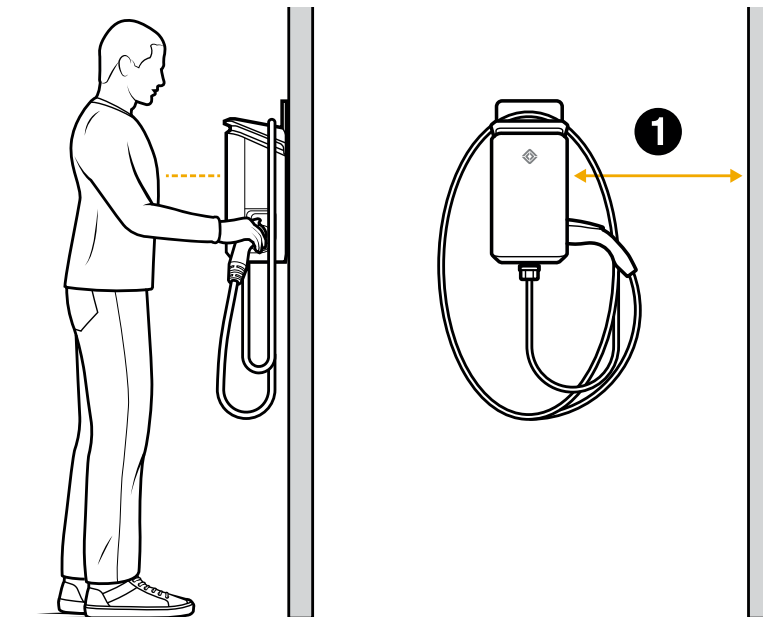

| Item | Description |
|------|--------------------------|
| 1 | At least 12 in (30.5 cm) |

ATTACH THE MOUNTING PLATE

NOTE

- Feed conduit only from the bottom when mounting the Wall Charger at an outdoor site.
- When installing on a concrete wall, select a fastener suitable for installation on concrete or stucco. Do not use the T20 fasteners provided with the product.

To a Concrete Wall

1. With the flat side of the mounting plate against the wall, and the large hole positioned in the lower-left, install a fastener in each of the four locations shown.

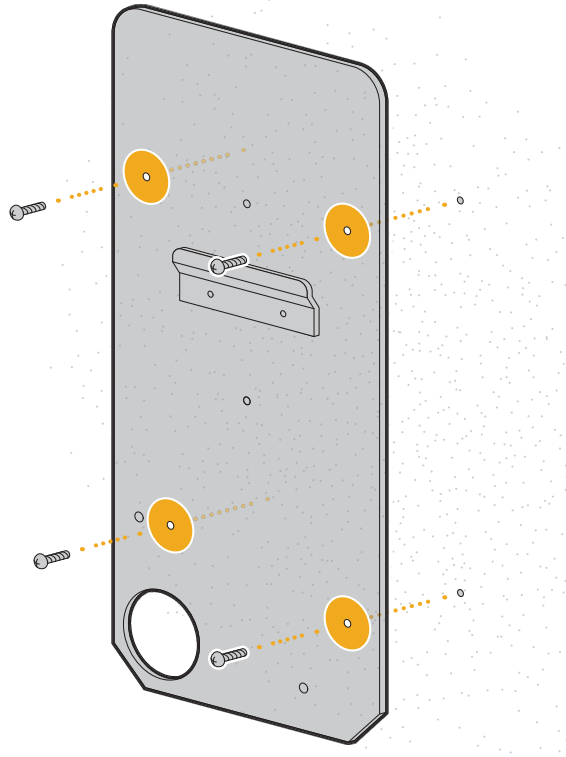

2. Use a level to confirm the plate is level.
3. Tighten the screws to secure the mounting plate to the wall. Ensure that both the screw and the wall are not damaged during installation.

To a Finished Wall Supported by Wooden Studs

1. Use a stud finder to locate the stud(s).
2. With the flat side of the mounting plate against the stud, and the large hole positioned in the lower-left, install the T20 screws in the locations shown.
 - For a vertical stud, install a screw in each of the three center holes.
 - For a horizontal stud:
 - a. Select a location where the horizontal and vertical studs meet.
 - b. Place the three holes in the upper third of the mounting plate against the horizontal stud and the three holes down the center of the mounting plate against the vertical stud.
 - c. Install a screw in each of the two outer holes in the upper third of the mounting plate.
 - d. Install a third screw in the lower center location of the mounting plate.

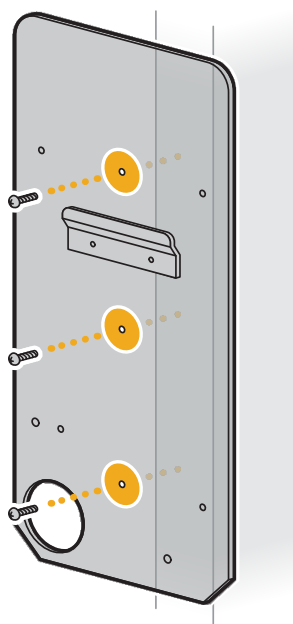

Vertical Stud Installation

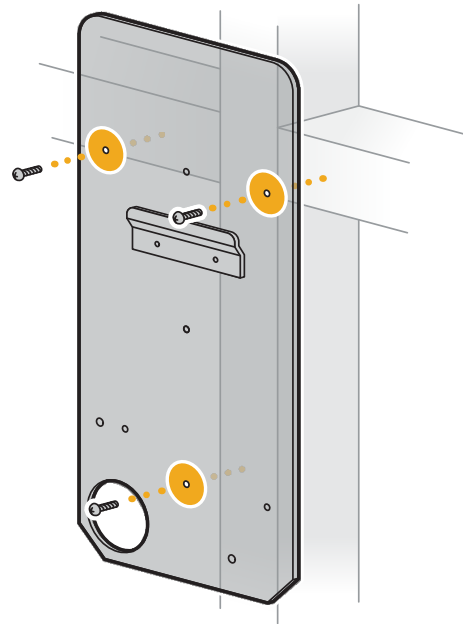

Horizontal Stud Installation

3. Tighten the screws in order to attach the mounting plate to the wall. Ensure that both the screw and the wall are not damaged during installation.

ATTACH THE WALL CHARGER TO THE MOUNTING PLATE

1. Determine which wire entry point to use in the Wall Charger—rear or bottom—and remove the cover.
 - For indoor installations where wire will run inside the wall, turn the rear wire entry cover counterclockwise to release it from the Wall Charger.

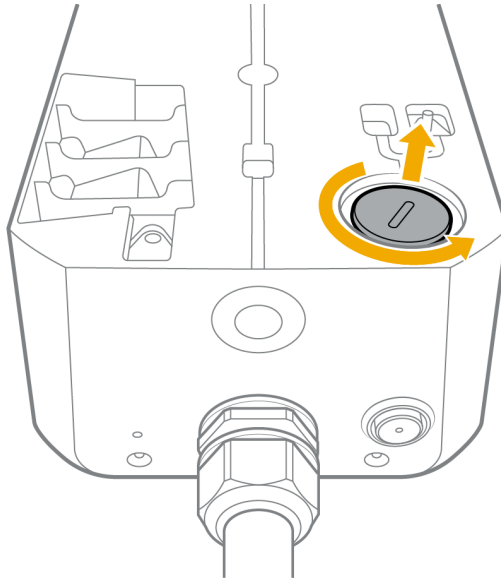

INSTALLATION

- For outdoor installations or indoor installations on concrete, knock out the 1 in (2.5 cm) or 0.5 in (1.3 cm) wire entry cover on the bottom of the Wall Charger. Remove the knock-out debris from the interior of the Wall Charger.

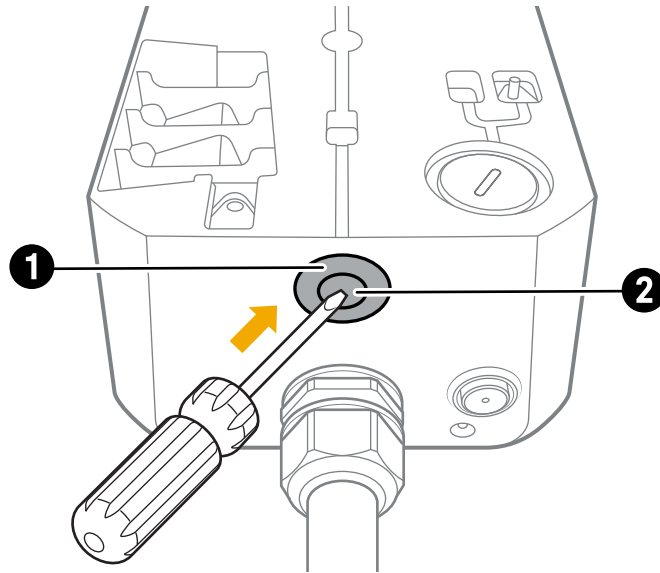

| Item | Description |
|------|-----------------|
| 1 | 1 in (2.5 cm) |
| 2 | 0.5 in (1.3 cm) |

INSTALLATION

2. Hang the Wall Charger on the installed mounting plate.

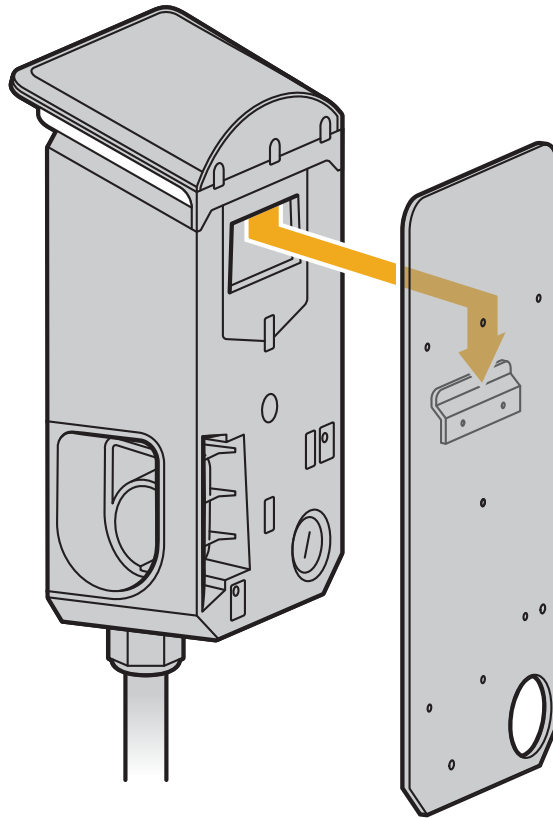



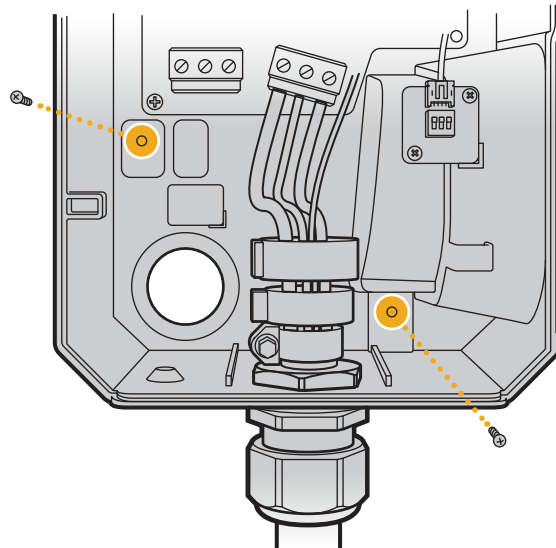





3. Use a #2 Phillips screwdriver to install the two 13 mm M4 screws through the interior of the Wall Charger into the mounting plate.



4. Torque each screw to 12 in-lb (1.36 N·m).

SET THE OPERATING CURRENT

Configure the dip switches to set the operating current.

| Current | Circuit Breaker Specification | Typical Conductor Specification* | Dip Switch | | | Figure |
|-------------------|-------------------------------|----------------------------------|------------|-----|-----|---------------------------------------------------------------------------------------|
| | | | 1 | 2 | 3 | |
| 6 A | 7.5 A | 12-14 AWG | OFF | OFF | OFF |  |
| 12 A | 15 A | 12-14 AWG | OFF | OFF | ON |  |
| 16 A | 20 A | 12-10 AWG | OFF | ON | OFF |  |
| 20 A | 25 A | 10 AWG | OFF | ON | ON |  |
| 24 A | 30 A | 10 AWG | ON | OFF | OFF |  |
| 32 A | 40 A | 8 AWG | ON | OFF | ON |  |
| 40 A | 50 A | 8 AWG | ON | ON | OFF |  |
| 48 A (default) | 60 A | 6 AWG | ON | ON | ON |  |

* Use only copper conductors. These typical conductor sizes are based on the 90°C column in the National Electrical Code.

CONNECT CONDUCTORS

Consult a licensed electrician to select a conductor size appropriate to the breaker size and to the maximum current set.

1. Depending on the type of installation, thread conduit or conductor fittings into the rear (1) or bottom (2) entry point in the Wall Charger. Ensure that the fittings are rated for the type and size of conductor used.

NOTE

For outdoor wall installations, insert through the bottom entry point only.

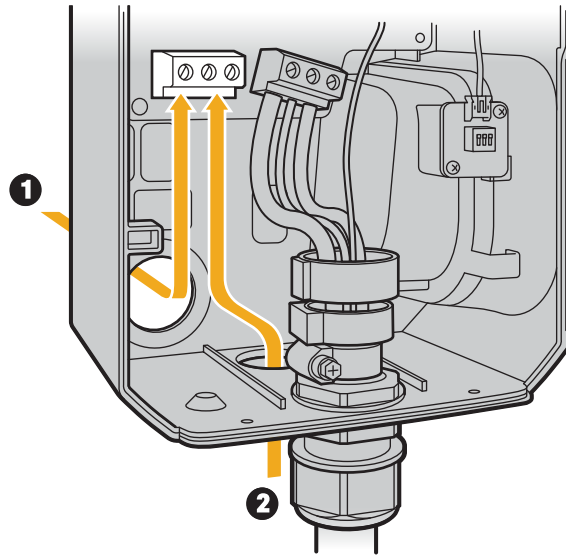

2. Strip the ends of the conductors 0.4 in (11 mm).
3. Fully insert the conductors into the corresponding terminals (L1, Ground, L2).

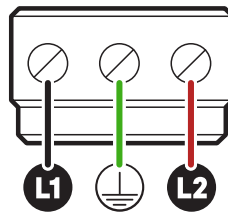

DANGER

Do not overtighten the terminals

4. Torque each terminal to 10.6 in-lb (1.2 N·m).
5. After energizing the charger, use a multimeter to test the voltages on the input terminal.

INSTALL THE FACEPLATE



CAUTION

- Use anti-static gloves, wrist bands connected to ground, and insulated tools for installation and removal of the faceplate.
- Avoid direct hand contact with components on the network board.
- Do not connect the cable if the charger is energized. Damage to the charger can occur.

1. Position the faceplate near the front of the Wall Charger.
2. Reconnect the cable from the Wall Charger to the network board on the interior of the faceplate.

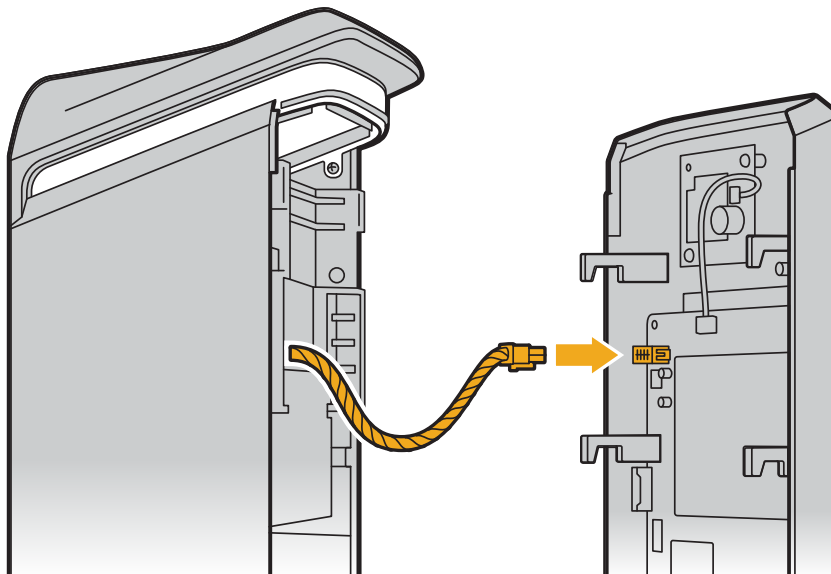

3. Slide the faceplate down onto the Wall Charger.
4. Install the two Security T20 Torx screws.
5. Torque each Security T20 Torx screw to 12 in-lb (1.36 N·m).

WRAP AND DOCK THE CABLE

Wrap the cable loosely around the Wall Charger and store the coupler in the dock on the side.

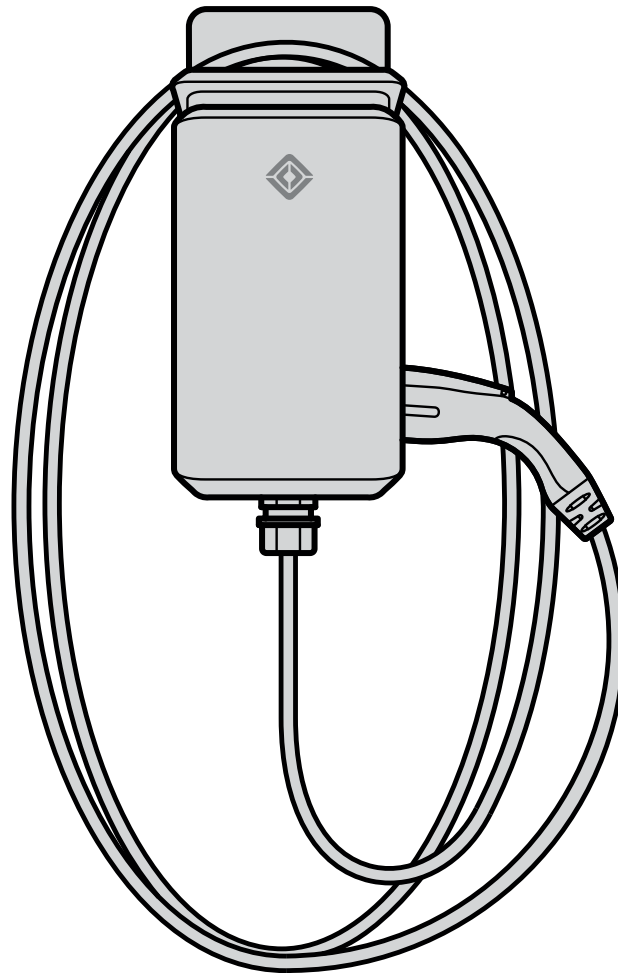

Connect to Wi-Fi

After installing the Wall Charger, connect it to your local Wi-Fi network and add it to your Rivian account. Doing this provides you with the ability to view charging status and allows the Wall Charger to:

- Receive automatic firmware updates
- Communicate helpful troubleshooting information directly to Rivian Customer Service

WHAT YOU NEED

To connect the Wall Charger to Wi-Fi, you will need the following:

- Mobile phone
- Rivian app downloaded and installed from the *App Store*® online store or on *Google Play*®
- Rivian account
- Stable 2.4 GHz Wi-Fi network within range of the Wall Charger

NOTES

- If the Wall Charger is located outside the range of the Wi-Fi signal, relocate the Wi-Fi modem or router within range or use a network extender.
- The Wall Charger may experience connection issues with certain wireless routers that blend 2.4 GHz and 5 GHz frequencies. Check your router settings to ensure 2.4 GHz is available. If you encounter a problem, [contact Rivian](#).

CONNECT TO THE WALL CHARGER

To connect to the Wall Charger, follow these steps:

1. Open the Rivian app on your phone.
2. Log in with your Rivian account name and password.
3. Open the Account menu and choose **Add gear**.
4. Choose **Wall Charger**.
5. Follow the instructions in the Rivian app to set up the Wall Charger and complete the connection process.

NOTES

- When the Rivian app instructs you to use the circuit breaker to turn the Wall Charger off and then on again, it may take up to 2 minutes for the Wall Charger to be discovered over *Bluetooth*®. Bluetooth will time out at the Wall Charger after a period of inactivity.
- You can associate the Wall Charger with only one Rivian account.

Light Bar States

| Light Bar | State | Indication |
|---------------------------|--------------|-----------------------------------------------------|
| White | Solid | End of charge session after unplugging from vehicle |
| White | Pulsing | Initializing |
| White (center light only) | Pulsing | Ready |
| Green | Pulsing | Charging |
| Green | Solid | Charging complete |
| Blue | Solid | Waiting to charge |
| Blue | Fast pulsing | Bluetooth communicating |
| Blue | Slow pulsing | Over-the-air (OTA) software update in progress |
| Red | Pulsing | Error (see Troubleshooting) |
| Red | Solid | Error (contact Rivian) |

Troubleshooting

If the Wall Charger light is pulsing red:

1. Unplug the charger from the vehicle.
2. Switch power off and then on again at the circuit breaker.
3. Allow the Wall Charger to boot up.

If the Wall Charger light is solid red:

1. Switch power off and then on again at the circuit breaker.
2. If this does not solve the issue, switch the power off again at the circuit breaker.
3. [Remove the faceplate](#) from the Wall Charger.
4. Confirm the dip switch configuration matches the installed circuit breaker.
5. [Install the faceplate](#), making sure to **reconnect the cable to the network board**.
6. Switch power on at the circuit breaker.

If the problem persists, [contact Rivian](#).

Power Off the Wall Charger



DANGER

Disconnect the power supply before removing or performing any maintenance on the Wall Charger. Failure to do so may result in physical injury or damage to the power supply system and the Wall Charger.

1. Open the breaker or disconnect immediately upstream of the Wall Charger.
2. Apply Lock Out/Tag Out.
3. Verify the absence of voltage.

Remove the Wall Charger

1. [Power off](#) the Wall Charger.
2. [Remove the faceplate](#) from the Wall Charger.
3. Use a voltage meter to confirm zero voltage at the terminals before proceeding.
4. Use a 7/32 in flat head screwdriver to loosen each of the three terminals (L1, Ground, and L2), and remove the conductors from the terminals.

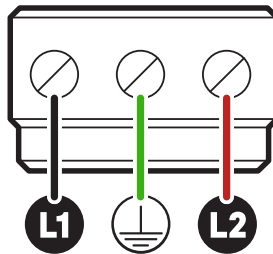

5. Carefully remove the conduit and fittings from the Wall Charger.

REMOVE THE WALL CHARGER

6. Remove the two #2 Phillips screws attaching the Wall Charger to the mounting plate.

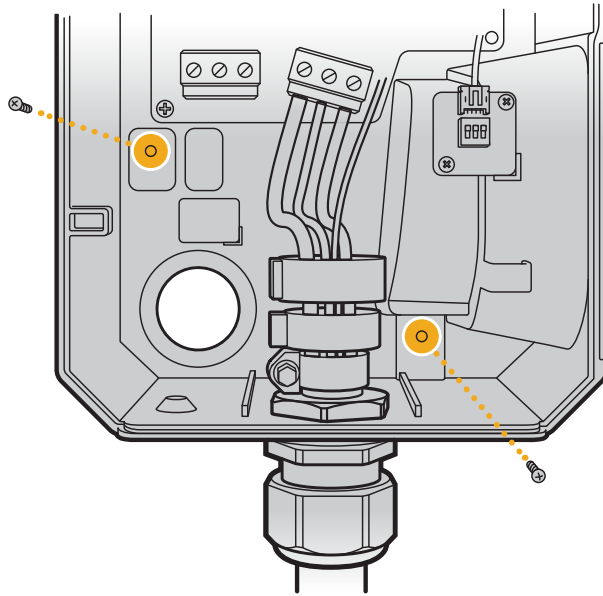

7. Lift the Wall Charger off of the mounting plate.

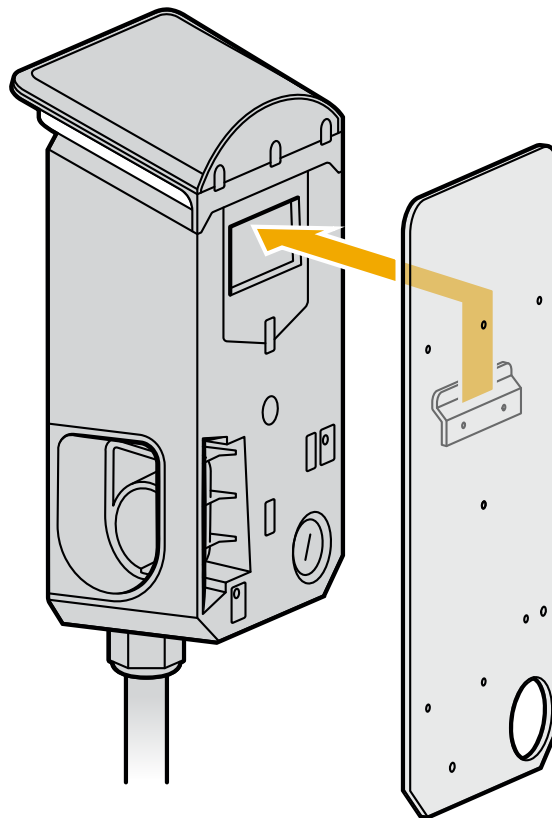

8. [Install the faceplate](#) on the Wall Charger.

Specifications

| Specification | Description |
|-----------------------------------------|---------------------------------------------------------------------------------|
| Voltage | 208/240 VAC (-20% – +15%), single-phase |
| Frequency | 60 Hz |
| Charging connector | SAE J1772 |
| Charging cable length | 25 ft (7.6 m) |
| Wi-Fi | IEEE 802.11 b/g/n |
| Network band | 2.4 GHz |
| Real-time clock | Yes (7 days) |
| Ethernet | 10/100BASE-T |
| Bluetooth | Supports Bluetooth 5.0 |
| Data protocol | OCPP 1.6; ISO 15118 capable |
| Metering accuracy | Embedded $\pm 1\%$ |
| Operating temperature | -22°F to 122°F (-30°C to 50°C) |
| Storage temperature | -40°F to 176°F (-40°C to 80°C) |
| Wiring type | Hard-wired |
| Acceptable conductor sizes | #14 to #6 AWG copper only (#6 AWG required for full 48 A continuous current) |
| Operating current | 6 A, 12 A, 16 A, 20 A, 24 A, 32 A, 40 A, 48 A (default, maximum) |
| Ground fault circuit interrupter (GFCI) | CCID 20 - EVSE will interrupt charging if leakage exceeds 20 mA |
| IP performance | NEMA Type 3R |
| Impact resistance | IK8 |
| Dimensions | Height: 16.3 in (41.4 cm) Width: 7.3 in (18.5 cm) Depth: 5.8 in (14.7 cm) |
| Weight | 24.25 lb (11 kg) including 25 ft (7.6 m) cable |
| Certification | UL 1998/2231/2594; FCC Part 15B |

| Specification | Description |
|----------------|-------------|
| UL file number | E520745 |
| Product number | PT00057325 |



Supplemental Information for Electrical Service Wiring

240V SPLIT-PHASE SYSTEM

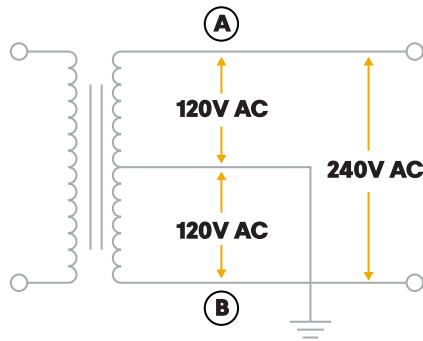



Federal Communication Commission Interference Statement

This equipment complies with part 15 of the FCC rules. Operation is subject to the following two conditions: (1) This equipment may not cause harmful interference, and (2) this equipment must accept any interference received, including interference that may cause undesired operation.

This equipment has been tested and found to comply with the limits for a Class B digital device, pursuant to Part 15 of the FCC rules. These limits are designed to provide reasonable protection against harmful interference in a residential installation. This equipment generates, uses, and can radiate radio frequency energy and, if not installed and used in accordance with the instructions, may cause harmful interference to radio communications. However, there is no guarantee that interference will not occur in a particular installation. If this equipment does cause harmful interference to radio or television reception, which can be determined by turning the equipment off and on, the user is encouraged to try to correct the interference by one or more of the following measures:

- Reorient or relocate the receiving antenna.
- Increase the separation between the equipment and receiver.
- Connect the equipment into an outlet on a circuit different from that to which the receiver is connected.
- Consult the dealer or an experienced radio/TV technician for help.

Changes or modifications not covered in this Guide must be approved in writing by the manufacturer's Regulatory Engineering Department. Changes or modifications made without written approval may void the user's authority to operate this equipment.

RF EXPOSURE INFORMATION

This device has been tested and meets applicable limits for Radio Frequency (RF) exposure. Keep a minimum distance of 8 in (20 cm) between you and the Wall Charger while installing or operating it.

Industry Canada Statement

This equipment complies with ISED's license-exempt RSSs. Operation is subject to the following two conditions: (1) This device may not cause harmful interference, and (2) this equipment must accept any interference received, including interference that may cause undesired operation.

RADIATION EXPOSURE STATEMENT

This equipment complies with ISED radiation exposure limits set forth for an uncontrolled environment. Keep a minimum distance of 8 in (20 cm) between you and the Wall Charger while installing or operating it.



Still need help? Connect with us.

Customer Service

Call (888) RIVIAN1 / (888) 748-4261

customerservice@rivian.com

rivian.com Support Center and Chat